



Brazed Heat Exchangers



The Brazed Heat Exchanger – less is more

The brazed plate heat exchanger is the most compact heat exchanger on the market today. Its high heat transfer efficiency in combination with its compact design equals a compact heat exchanger for a wide range of heating, cooling, evaporating and condensing duties.

The brazed heat exchanger consists of thin corrugated stainless steel plates brazed together with copper to form a self-contained unit. Brazing the plates together eliminates the need for a frame, gaskets, bolts and the carrying bar. The result is a heat exchanger that costs less, weighs less, holds less refrigerant and takes up less space.

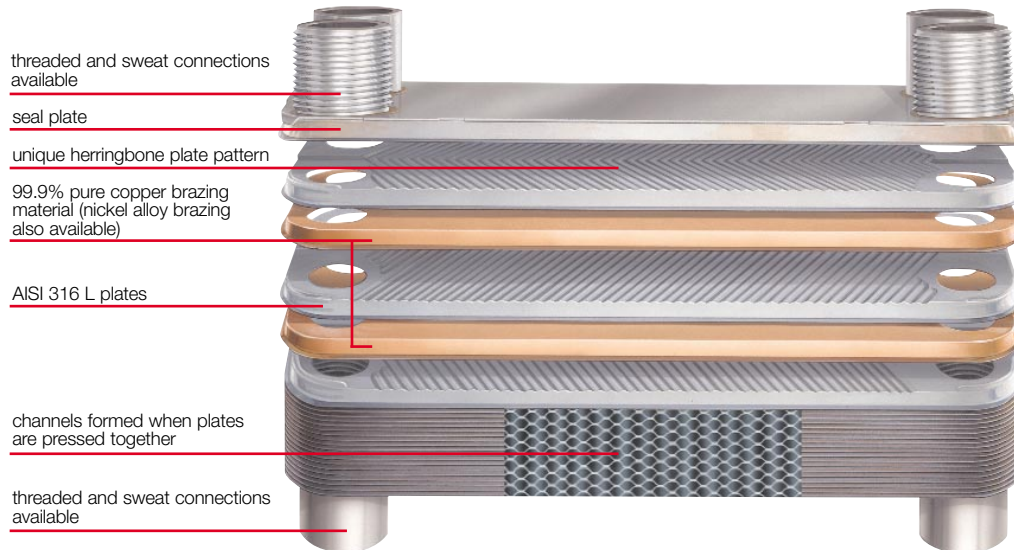

Brazed Heat Exchangers Product Catalog

How a BHE works

The Brazed Heat Exchanger is a compact variation of the Plate Heat Exchanger. It consists of a series of channel plates, a front cover and a back cover plate, as well as a seal plate and connections. The channel plates are made of AISI 316 stainless steel stamped with a herringbone pattern. The channel plates are arranged so that the herringbone pattern of adjacent plates points in opposite directions. This creates a criss-cross pattern of support points where the ridges of each plate meet.

The plates are brazed together with 99.9 percent pure copper, thereby sealing the contact points and forming continuous media flow channels. Brazing around the outer edge of the plates and connections creates a completely sealed unit. For duties where copper is not appropriate, such as deionized water or ammonia, nickel brazing alloy may be used.

Media enter the inlet connections and are distributed into the narrow channels between the plates. The plates are arranged so that the two media can flow in either co-current or countercurrent flow.

The thin plate material, corrugated plate pattern and fluid turbulence all contribute to high heat transfer coefficients which results in a more compact heat exchanger. This, in turn, means lower hold-up volumes, simplified installation and lower shipping costs. Alfa Laval's Brazed Heat Exchangers are UL and CUL Listed according to Underwriters Laboratories file number SA7094.

A unique refrigeration laboratory

Alfa Laval is the only heat exchanger manufacturer with a refrigeration laboratory dedicated to testing heat exchangers – all without any cost to the customer. This ensures the customer that the heat exchanger ordered is precisely adapted to fit a particular refrigeration duty.

Alfa Laval's state-of-the-art refrigeration laboratory can test evaporators, condensers, subcoolers, desuperheaters, process fluid coolers as well as complete package liquid chillers with capacities ranging from a fraction of a ton to 100 tons with R22 at ARI conditions. The test equipment can handle flow rates ranging from 0 to 250 gpm. AC frequency drives can vary compressor frequencies in infinite capacity increments

up to 100 tons and test rigs can be adapted to fit the customer's piping specifications.

Computerized control systems can maintain temperatures within an accuracy of $\pm 0.2^{\circ}\text{F}$ and flow rates with an accuracy of $\pm 0.5\text{gpm}$. An advanced data acquisition system collects up to 48 temperatures and 28 pressures and 10 flow readings.

For more information visit us at:
www.alfalaval.us

Brazed Plate Heat Exchanger model specifications

Specifications	CB14	CB27	CB52	CB76	AC50	AC80	AC120	AC130	AC250	CB200	CB300
Pressure Range (PSIG)	Vacuum to 500	Vacuum to 450	Vacuum to 450	Vacuum to 435	Vacuum to 450	Vacuum to 464	Vacuum to 450	Vacuum to 435/450	Vacuum to 362/450	Vacuum to 300/370	Vacuum to 300/370
Temperature Range (°F)	-256°F to 437°F	-256°F to 437°F	-256°F to 437°F	-256°F to 437°F	-256°F to 437°F	-256°F to 437°F	-256°F to 437°F	-256°F to 437°F	-256°F to 437°F	-256°F to 437°F	-256°F to 437°F
Max. Connection Size (in.)	3/4	1-1/8	1-1/8	2-1/2	1-3/8	1-3/8	2-1/2	2-1/2	3-1/8	3	4-1/8
Max. Flow Rate (gpm)	16	40	40	150	79	79	150	150	460	615	1615/256
Volume/Channel (gallons)	0.005	0.013	0.021	0.066	0.025	0.025	0.053	0.043	0.100	0.13	0.172
Height (in.)	8.23	12.2	20.71	24.29	20.71	15.4	24.29	19.18	33.50	31.48	48.15
Width (in.)	3.07	4.41	4.41	7.56	4.41	7.7	7.56	9.73	12.68	15.74	14.37
Length Calculations (in.)	.32+(n*.095)	.35+(n*.095)	.39+(n*.094)	.39+(n*.111)	.39+(n*.095)	.39+(n*.095)	.45+(n*.094)	.31+(n*.088)	.53+(n*.111)	.63+(n*.103)	.63+(n*.103)
Weight Calculations (lbs.)	1.5+(n*.13)	2.6+(n*.29)	4.0+(n*.51)	16.8+(n*.97)	4.0+(n*.51)	4.0+(n*.51)	16.8+(n*.97)	14.3+(n*.84)	22.3+(n*1.76)	29+(n*1.32)	125.7+(n*2.78)

*Channels S1 & S2/Channels S3 & S4
All Alfa Laval copper brazed heat exchangers are UL/cUL Listed.
n= number of plates

Introduction

MODEL SPECIFICATIONS

Refrigerant Applications (nominal tons*)

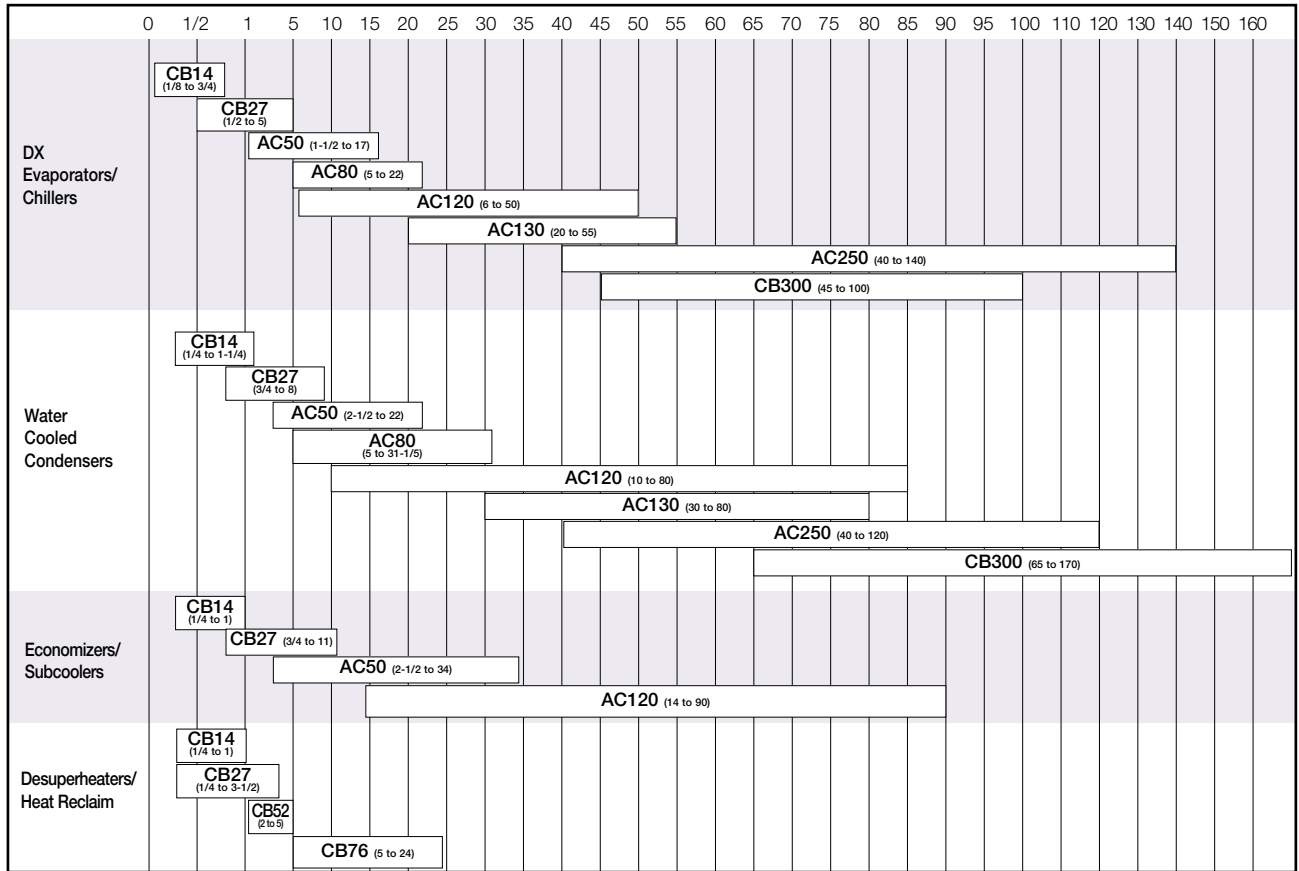

*ARI Conditions

Introduction

PRODUCT RANGE BY APPLICATION

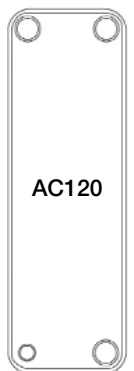
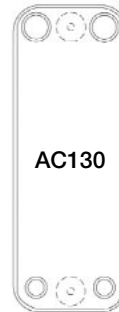
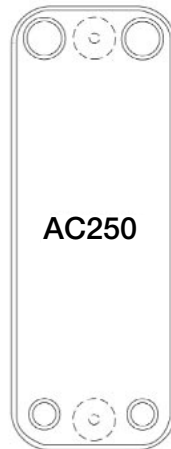

Non-Refrigerant Applications (kBTU/hr*)

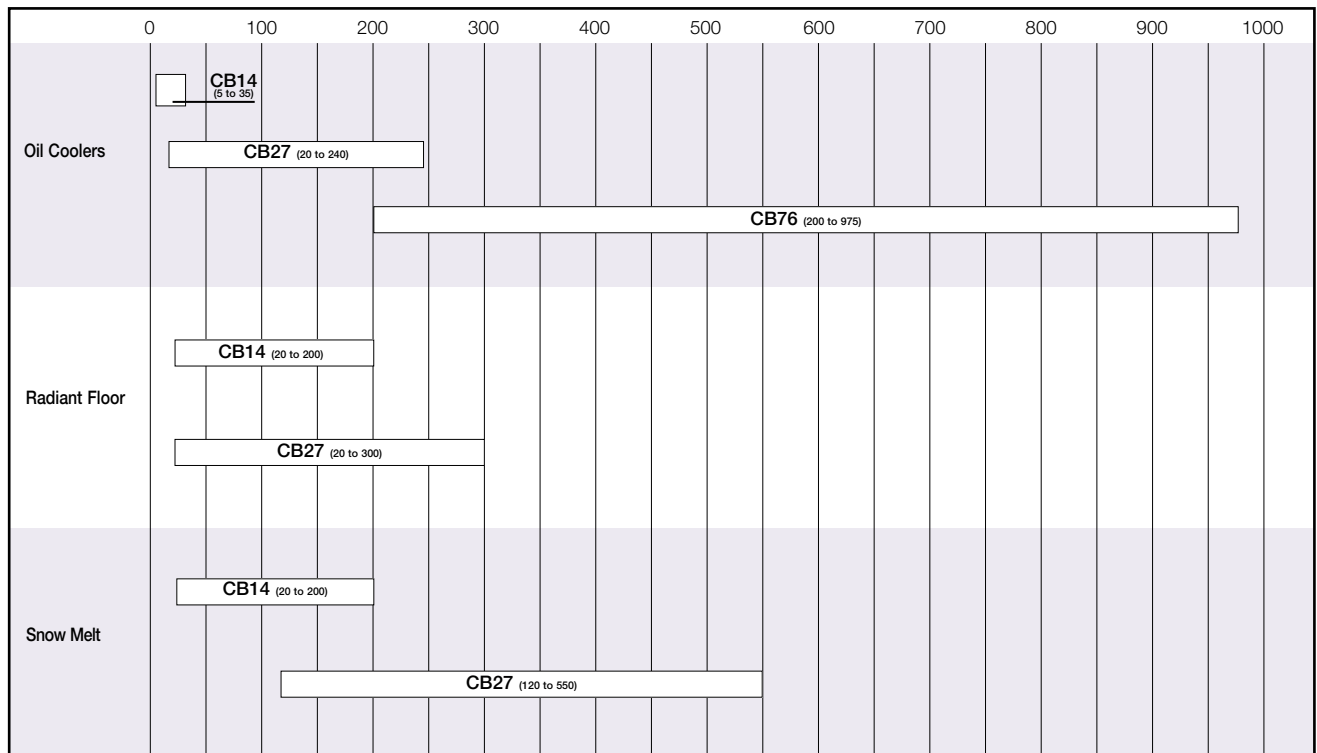

*ARI Conditions

Introduction

PRODUCT RANGE BY APPLICATION

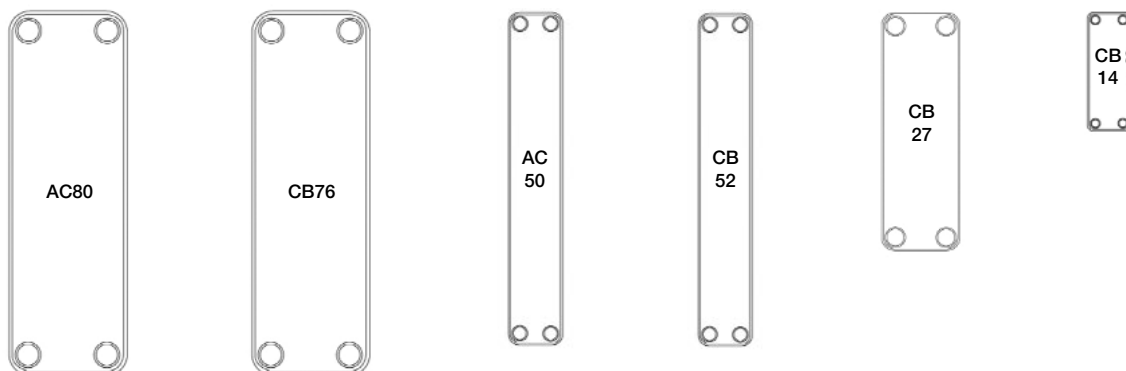

Evaporators use refrigerant to remove heat from a cooling fluid or a process fluid. The refrigerant absorbs the heat by changing from the liquid state to vapor state via direct expansion. Brazed plate heat exchangers, when used as evaporators, are used to cool process fluids, secondary cooling fluids and air conditioning fluids.

The saturated suction temperature of the refrigerant is typically about 9°F lower than the outlet temperature of the fluid being chilled.

DX Evaporators/Chillers

DX Evaporators/Chillers

Nominal Tons*	Denomination	Part Number	Connection Description		Operating Charge (R22)****	Dry Wt. (lbs.)	Dimensions		
			Refrigerant Inlet/Outlet (S3, S4)	Fluid Inlet/Outlet (S1, S2)			Height (in.)	Width (in.)	Plate Pack Length (in.)
Single Circuited									
0.25	CB14- 14H S15	3287000755	5/8" Sweat	5/8" Sweat	0.05	3.4	8.19	3.07	1.61
0.75	CB27- 12H S15	3287000754	5/8" Sweat	5/8" Sweat	0.1	6.1	12.2	4.41	1.49
1.5	CB27- 18H S33	3287000712	7/8" Sweat	7/8" Sweat	0.17	7.8	12.2	4.41	2.06
2	CB27- 24H S33	3287000713	7/8" Sweat	7/8" Sweat	0.23	9.5	12.2	4.41	2.62
3	CB27- 34H S52	3287000714	1-1/8" Sweat	1-1/8" Sweat	0.34	12.4	12.2	4.41	3.57
4	CB27- 44H S52	3287000562	1-1/8" Sweat	1-1/8" Sweat	0.44	15.3	12.2	4.41	4.51
5	CB27- 54H S52	3287000563	1-1/8" Sweat	1-1/8" Sweat	0.54	18.1	12.2	4.41	5.46
6	CB27- 64H S52	3287000564	1-1/8" Sweat	1-1/8" Sweat	0.65	21	12.2	4.41	6.4
3	AC50- 16HX S11	3287000709	1/2", 1-1/8" Sweat	1-1/8" Sweat	0.28	12.1	20.71	4.41	1.89
4	AC50- 20HX S11	3287000710	1/2", 1-1/8" Sweat	1-1/8" Sweat	0.36	14.1	20.71	4.41	2.28
5	AC50- 26HX S21	3287000715	5/8", 1-1/8" Sweat	1-1/8" Sweat	0.48	17.2	20.71	4.41	2.84
6	AC50- 32HX S21	3287000716	5/8", 1-1/8" Sweat	1-1/8" Sweat	0.6	20.2	20.71	4.41	3.43
7	AC50- 36HX S21	3287000717	5/8", 1-1/8" Sweat	1-1/8" Sweat	0.68	22.2	20.71	4.41	3.78
8	AC50- 42HX S21	3287000718	5/8", 1-1/8" Sweat	1-1/8" Sweat	0.8	25.3	20.71	4.41	4.37
9	AC50- 48HX S24	3287000719	5/8", 1-3/8" Sweat	1-1/8" Sweat	0.92	28.3	20.71	4.41	4.91
10	AC50- 54HX S24	3287000720	5/8", 1-3/8" Sweat	1-1/8" Sweat	1.04	31.4	20.71	4.41	5.51
11	AC50- 64HX S25	3287000721	5/8", 1-3/8" Sweat	1-3/8" Sweat	1.24	36.4	20.71	4.41	6.46
12	AC50- 70HX S25	3287000722	5/8", 1-3/8" Sweat	1-3/8" Sweat	1.36	39.5	20.71	4.41	7.01
10	AC120- 30EQ S46	3287000696	7/8", 2-1/8" Sweat	2-1/8" Sweat, 2-1/8" Sweat	1.2	45.8	24.29	7.56	3.21
12.5	AC120- 40EQ S46	3287000697	7/8", 2-1/8" Sweat	2-1/8" Sweat, 2-1/8" Sweat	1.61	55.6	24.29	7.56	4.13
15	AC120- 46EQ S62	3287000698	1-1/8", 2-1/8" Sweat	2-1/8" Sweat, 2-1/8" Sweat	1.88	61.4	24.29	7.56	4.69
20	AC120- 60EQ S62	3287000699	1-1/8", 2-1/8" Sweat	2-1/8" Sweat, 2-1/8" Sweat	2.48	75	24.29	7.56	5.98
25	AC120- 76EQ S62	3287000700	1-1/8", 2-1/8" Sweat	2-1/8" Sweat, 2-1/8" Sweat	3.15	90.5	24.29	7.56	7.46
30	AC120- 90EQ S62	3287000701	1-1/8", 2-1/8" Sweat	2-1/8" Sweat, 2-1/8" Sweat	3.76	104.1	24.29	7.56	8.76
35	AC120- 106EQ S62	3287000702	1-1/8", 2-1/8" Sweat	2-1/8" Sweat, 2-1/8" Sweat	4.42	119.6	24.29	7.56	10.24
40	AC120- 124EQ S62	3287000703	1-1/8", 2-1/8" Sweat	2-1/8" Sweat, 2-1/8" Sweat	5.19	137	24.29	7.56	11.91
48	AC120- 150EQ S76	3287000704	1-3/8", 2-1/8" Sweat	2-1/8" Sweat, 2-1/8" Sweat	6.32	162.3	24.29	7.56	14.31
55	AC120- 180EQ S76	3287000705	1-3/8", 2-1/8" Sweat	2-1/8" Sweat, 2-1/8" Sweat	7.6	191.4	24.29	7.56	17.09
			Refrigerant Inlet/Outlet (S3.1, S4.1)**	Fluid Inlet/Outlet (T1, T2)***					
40	AC250- 60EQ Y51	3287000756	1-1/8", 2-5/8" Sweat	3" Victaulic	4.67	134.5	33.5	12.68	7.38
50	AC250- 80EQ Y55	3287000757	1-3/8", 2-5/8" Sweat	3" Victaulic	6.28	169.8	33.5	12.68	9.67
60	AC250- 100EQ Y55	3287000758	1-3/8", 2-5/8" Sweat	3" Victaulic	7.89	205	33.5	12.68	11.95
75	AC250- 120EQ Y57	3287000759	1-3/8", 3-1/8" Sweat	3" Victaulic	9.51	240.3	33.5	12.68	14.23
100	AC250- 180EQ Y98	3287000760	42 mm, 3-1/8" Sweat	3" Victaulic	14.34	346.1	33.5	12.68	21.08
120	AC250- 250EQ Y98	3287000761	42 mm, 3-1/8" Sweat	3" Victaulic	19.98	469.6	33.5	12.68	29.07
Dual Circuited									
			Refrigerant Inlet/Outlet (S3.1,2, S4.1,2)**	Fluid Inlet/Outlet (T1, T2)***					
5	AC80- 30DQ Q18	3287000711	5/8", 1-1/8" Sweat	1-3/8" Sweat	0.56	23.6	15.35	7.68	2.8
7.5	AC80- 42DQ Q18	3287000706	5/8", 1-1/8" Sweat	1-3/8" Sweat	0.8	30	15.35	7.68	3.7
10	AC80- 54DQ Q18	3287000732	5/8", 1-1/8" Sweat	1-3/8" Sweat	1.04	36.4	15.35	7.68	4.65
12.5	AC80- 66DQ Q18	3287000733	5/8", 1-1/8" Sweat	1-3/8" Sweat	1.28	42.8	15.35	7.68	5.55
15	AC80- 82DQ Q18	3287000734	5/8", 1-1/8" Sweat	1-3/8" Sweat	1.6	51.4	15.35	7.68	6.81
17	AC80- 98DQ Q19	3287000735	7/8", 1-3/8" Sweat	1-3/8" Sweat	1.92	59.9	15.35	7.68	8.03
20	AC80- 118DQ Q19	3287000736	7/8", 1-3/8" Sweat	1-3/8" Sweat	2.32	70.6	15.35	7.68	9.57
20	AC130- 70DQ Y97	3287000752	7/8", 1-5/8" Sweat	2-1/2" Victaulic	2.35	73	19.17	9.72	6.36
25	AC130- 82DQ Y97	3287000737	7/8", 1-5/8" Sweat	2-1/2" Victaulic	2.76	83	19.17	9.72	7.52
30	AC130- 102DQ Y97	3287000738	7/8", 1-5/8" Sweat	2-1/2" Victaulic	3.45	99.8	19.17	9.72	9.25
35	AC130- 122DQ Y74	3287000739	1-1/8", 2-1/8" Sweat	2-1/2" Victaulic	4.14	116.6	19.17	9.72	11.02
40	AC130- 142DQ Y74	3287000740	1-1/8", 2-1/8" Sweat	2-1/2" Victaulic	4.82	133.3	19.17	9.72	12.8
45	AC130- 162DQ Y74	3287000741	1-1/8", 2-1/8" Sweat	2-1/2" Victaulic	5.52	150	19.17	9.72	14.53
50	AC130- 182DQ Y74	3287000742	1-1/8", 2-1/8" Sweat	2-1/2" Victaulic	6.2	166.8	19.17	9.72	16.3
55	AC130- 202DQ Y74	3287000743	1-1/8", 2-1/8" Sweat	2-1/2" Victaulic	6.89	183.6	19.17	9.72	18.03
60	AC250- 102DQ Y77	3287000726	1-1/8", 2-5/8" Sweat	3" Victaulic	8.02	208.6	33.5	12.68	12.18
75	AC250- 122DQ Y77	3287000707	1-1/8", 2-5/8" Sweat	3" Victaulic	9.62	243.8	33.5	12.68	14.46
90	AC250- 142DQ Y81	3287000727	1-3/8", 2-5/8" Sweat	3" Victaulic	11.22	279.1	33.5	12.68	16.74
100	AC250- 162DQ Y81	3287000728	1-3/8", 2-5/8" Sweat	3" Victaulic	12.83	314.4	33.5	12.68	19.03
105	AC250- 182DQ Y81	3287000729	1-3/8", 2-5/8" Sweat	3" Victaulic	14.43	349.7	33.5	12.68	21.31
115	AC250- 202DQ Y81	3287000730	1-3/8", 2-5/8" Sweat	3" Victaulic	16.03	384.9	33.5	12.68	23.59
130	AC250- 250DQ Y99	3287000753	1-3/8", 3-1/8" Sweat	3" Victaulic	19.88	469.6	33.5	12.68	29.07

*Operating Conditions: 54°F EWT, 44°F LWT, 35°F SST, 7"SH&P_w<10psig, FF=0.0001Ft², hr, °F/Btu

**Diagonal flow connections

***Fluid connections on back side standard, front side optional

****Estimated 15% liquid on S3-S4 side

Brazed plate heat exchangers use water to cool the refrigerant in a condensing application. The cooling water desuperheats and condenses the refrigerant vapor coming off the compressor. Water-cooled condensers are much smaller and require less refrigerant piping than air-cooled condensers. Typically, the cooling water is about 20°F lower than the refrigerant condensing temperature.

Water-Cooled Condensers

Water-Cooled Condensers

Nominal Tons*	Denomination	Part Number	Connection Description		Operating Charge (R22)****	Dry Wt. (lbs.)	Dimensions			
			Refrigerant Inlet/Outlet (S3, S4)	Fluid Inlet/Outlet (S1, S2)			Height (in.)	Width (in.)	Plate Pack Length (in.)	
Single Circuited										
0.25	CB14- 14H S15	3287000755	5/8" Sweat	5/8" Sweat	0.05	3.4	8.19	3.07	1.61	
1	CB27- 12H S15	3287000754	5/8" Sweat	5/8" Sweat	0.1	6.1	12.2	4.41	1.49	
1.75	CB27- 18H S33	3287000712	7/8" Sweat	7/8" Sweat	0.17	7.8	12.2	4.41	2.06	
2.5	CB27- 24H S33	3287000713	7/8" Sweat	7/8" Sweat	0.23	9.5	12.2	4.41	2.62	
3.5	CB27- 34H S52	3287000714	1-1/8" Sweat	1-1/8" Sweat	0.34	12.4	12.2	4.41	3.57	
4.75	CB27- 44H S52	3287000562	1-1/8" Sweat	1-1/8" Sweat	0.44	15.3	12.2	4.41	4.51	
6	CB27- 54H S52	3287000563	1-1/8" Sweat	1-1/8" Sweat	0.54	18.1	12.2	4.41	5.46	
7	CB27- 64H S52	3287000564	1-1/8" Sweat	1-1/8" Sweat	0.65	21	12.2	4.41	6.4	
3.5	AC50- 16HX S11	3287000709	1/2", 1-1/8" Sweat	1-1/8" Sweat	0.28	12.1	20.71	4.41	1.89	
4.5	AC50- 20HX S11	3287000710	1/2", 1-1/8" Sweat	1-1/8" Sweat	0.36	14.1	20.71	4.41	2.28	
6	AC50- 26HX S21	3287000715	5/8", 1-1/8" Sweat	1-1/8" Sweat	0.48	17.2	20.71	4.41	2.84	
7	AC50- 32HX S21	3287000716	5/8", 1-1/8" Sweat	1-1/8" Sweat	0.6	20.2	20.71	4.41	3.43	
8.5	AC50- 36HX S21	3287000717	5/8", 1-1/8" Sweat	1-1/8" Sweat	0.68	22.2	20.71	4.41	3.78	
10	AC50- 42HX S21	3287000718	5/8", 1-1/8" Sweat	1-1/8" Sweat	0.8	25.3	20.71	4.41	4.37	
12	AC50- 48HX S24	3287000719	5/8", 1-3/8" Sweat	1-1/8" Sweat	0.92	28.3	20.71	4.41	4.91	
13	AC50- 54HX S24	3287000720	5/8", 1-3/8" Sweat	1-1/8" Sweat	1.04	31.4	20.71	4.41	5.51	
14	AC50- 64HX S25	3287000721	5/8", 1-3/8" Sweat	1-3/8" Sweat	1.24	36.4	20.71	4.41	6.46	
15	AC50- 70HX S25	3287000722	5/8", 1-3/8" Sweat	1-3/8" Sweat	1.36	39.5	20.71	4.41	7.01	
14	AC120- 30EQ S46	3287000696	7/8", 2-1/8" Sweat	2-1/8" Sweat, 2-1/8" Sweat	1.2	45.8	24.29	7.56	3.21	
19	AC120- 40EQ S46	3287000697	7/8", 2-1/8" Sweat	2-1/8" Sweat, 2-1/8" Sweat	1.61	55.6	24.29	7.56	4.13	
22	AC120- 46EQ S62	3287000698	1-1/8", 2-1/8" Sweat	2-1/8" Sweat, 2-1/8" Sweat	1.88	61.4	24.29	7.56	4.69	
28	AC120- 60EQ S62	3287000699	1-1/8", 2-1/8" Sweat	2-1/8" Sweat, 2-1/8" Sweat	2.48	75	24.29	7.56	5.98	
35	AC120- 76EQ S62	3287000700	1-1/8", 2-1/8" Sweat	2-1/8" Sweat, 2-1/8" Sweat	3.15	90.5	24.29	7.56	7.46	
40	AC120- 90EQ S62	3287000701	1-1/8", 2-1/8" Sweat	2-1/8" Sweat, 2-1/8" Sweat	3.76	104.1	24.29	7.56	8.76	
47	AC120-106EQ S62	3287000702	1-1/8", 2-1/8" Sweat	2-1/8" Sweat, 2-1/8" Sweat	4.42	119.6	24.29	7.56	10.24	
53	AC120-124EQ S62	3287000703	1-1/8", 2-1/8" Sweat	2-1/8" Sweat, 2-1/8" Sweat	5.19	137	24.29	7.56	11.91	
62	AC120-150EQ S76	3287000704	1-3/8", 2-1/8" Sweat	2-1/8" Sweat, 2-1/8" Sweat	6.32	162.3	24.29	7.56	14.31	
70	AC120-180EQ S76	3287000705	1-3/8", 2-1/8" Sweat	2-1/8" Sweat, 2-1/8" Sweat	7.6	191.4	24.29	7.56	17.09	
			Refrigerant Inlet/Outlet (S3.1, S4.1)**	Fluid Inlet/Outlet (T1, T2)***						
40	AC250- 60EQ Y51	3287000756	1-1/8", 2-5/8" Sweat	3" Victaulic	4.67	134.5	33.5	12.68	7.38	
50	AC250- 80EQ Y55	3287000757	1-3/8", 2-5/8" Sweat	3" Victaulic	6.28	169.8	33.5	12.68	9.67	
60	AC250-100EQ Y55	3287000758	1-3/8", 2-5/8" Sweat	3" Victaulic	7.89	205	33.5	12.68	11.95	
75	AC250-120EQ Y57	3287000759	1-3/8", 3-1/8" Sweat	3" Victaulic	9.51	240.3	33.5	12.68	14.23	
100	AC250-180EQ Y98	3287000760	42 mm, 3-1/8" Sweat	3" Victaulic	14.34	346.1	33.5	12.68	21.08	
120	AC250-250EQ Y98	3287000761	42 mm, 3-1/8" Sweat	3" Victaulic	19.98	469.6	33.5	12.68	29.07	
			Refrigerant Inlet/Outlet (S3.1,2, S4.1,2)**	Fluid Inlet/Outlet (T1, T2)***						
7.5	AC80- 30DQ Q18	3287000711	5/8", 1-1/8" Sweat	1-3/8" Sweat	0.56	23.6	15.35	7.68	2.8	
10.5	AC80- 42DQ Q18	3287000706	5/8", 1-1/8" Sweat	1-3/8" Sweat	0.8	30	15.35	7.68	3.7	
14	AC80- 54DQ Q18	3287000732	5/8", 1-1/8" Sweat	1-3/8" Sweat	1.04	36.4	15.35	7.68	4.65	
17	AC80- 66DQ Q18	3287000733	5/8", 1-1/8" Sweat	1-3/8" Sweat	1.28	42.8	15.35	7.68	5.55	
21.5	AC80- 82DQ Q18	3287000734	5/8", 1-1/8" Sweat	1-3/8" Sweat	1.6	51.4	15.35	7.68	6.81	
26	AC80- 98DQ Q19	3287000735	7/8", 1-3/8" Sweat	1-3/8" Sweat	1.92	59.9	15.35	7.68	8.03	
31.5	AC80-118DQ Q19	3287000736	7/8", 1-3/8" Sweat	1-3/8" Sweat	2.32	70.6	15.35	7.68	9.57	
30	AC130- 70DQ Y97	3287000752	7/8", 1-5/8" Sweat	2-1/2" Victaulic	2.35	73	19.17	9.72	6.36	
35	AC130- 82DQ Y97	3287000737	7/8", 1-5/8" Sweat	2-1/2" Victaulic	2.76	83	19.17	9.72	7.52	
43	AC130-102DQ Y97	3287000738	7/8", 1-5/8" Sweat	2-1/2" Victaulic	3.45	99.8	19.17	9.72	9.25	
50	AC130-122DQ Y74	3287000739	1-1/8", 2-1/8" Sweat	2-1/2" Victaulic	4.14	116.6	19.17	9.72	11.02	
57	AC130-142DQ Y74	3287000740	1-1/8", 2-1/8" Sweat	2-1/2" Victaulic	4.82	133.3	19.17	9.72	12.8	
63	AC130-162DQ Y74	3287000741	1-1/8", 2-1/8" Sweat	2-1/2" Victaulic	5.52	150	19.17	9.72	14.53	
69	AC130-182DQ Y74	3287000742	1-1/8", 2-1/8" Sweat	2-1/2" Victaulic	6.2	166.8	19.17	9.72	16.3	
74	AC130-202DQ Y74	3287000743	1-1/8", 2-1/8" Sweat	2-1/2" Victaulic	6.89	183.6	19.17	9.72	18.03	
60	AC250-102DQ Y77	3287000726	1-1/8", 2-5/8" Sweat	3" Victaulic	8.02	208.6	33.5	12.68	12.18	
75	AC250-122DQ Y77	3287000707	1-1/8", 2-5/8" Sweat	3" Victaulic	9.62	243.8	33.5	12.68	14.46	
83	AC250-142DQ Y81	3287000727	1-3/8", 2-5/8" Sweat	3" Victaulic	11.22	279.1	33.5	12.68	16.74	
92	AC250-162DQ Y81	3287000728	1-3/8", 2-5/8" Sweat	3" Victaulic	12.83	314.4	33.5	12.68	19.03	
100	AC250-182DQ Y81	3287000729	1-3/8", 2-5/8" Sweat	3" Victaulic	14.43	349.7	33.5	12.68	21.31	
105	AC250-202DQ Y81	3287000730	1-3/8", 2-5/8" Sweat	3" Victaulic	16.03	384.9	33.5	12.68	23.59	
120	AC250-250DQ Y99	3287000753	1-3/8", 3-1/8" Sweat	3" Victaulic	19.88	469.6	33.5	12.68	29.07	

*Operating Conditions: 195°F EGT, 105°F SCT, 5°F Subcooling, 85°F EWT, 95°F LWT, $\Delta P_{ref} < 5$ psig, $\Delta P_w < 10$ psig.

FF = 0.0001 Ft³/hr, °F/Btu

Note: 1 Ton = 15,000 $\frac{Btu}{hr}$

**Diagonal flow connections

***Fluid connections on back side, front side optional

****Estimated 20% liquid on S3-S4 side

Economizers use evaporating refrigerant to subcool liquid refrigerant from the condenser. The evaporating refrigerant absorbs the heat by changing from the liquid state to vapor state via direct expansion. The subcooled refrigerant enhances system efficiency and capacity. Brazed plate heat exchangers are commonly used as economizers in low temperature applications such as those in supermarkets and food processing.

Economizers/Subcoolers

Economizers/Subcoolers

Nominal Tons*	Denomination	Part Number	Connection Description		Operating Charge (R22)****	Dry Wt. (lbs.)	Dimensions		
			Refrigerant Inlet/Outlet (S3, S4)	Fluid Inlet/Outlet (S1, S2)			Height (in.)	Width (in.)	Plate Pack Length (in.)
Single Circuited									
0.5	CB14- 14H S15	3287000755	5/8" Sweat	5/8" Sweat	0.05	3.4	8.19	3.07	1.61
1.5	CB27- 12H S15	3287000754	5/8" Sweat	5/8" Sweat	0.1	6.1	12.2	4.41	1.49
2.5	CB27- 18H S33	3287000712	7/8" Sweat	7/8" Sweat	0.17	7.8	12.2	4.41	2.06
3.5	CB27- 24H S33	3287000713	7/8" Sweat	7/8" Sweat	0.23	9.5	12.2	4.41	2.62
5	CB27- 34H S52	3287000714	1-1/8" Sweat	1-1/8" Sweat	0.34	12.4	12.2	4.41	3.57
7	CB27- 44H S52	3287000562	1-1/8" Sweat	1-1/8" Sweat	0.44	15.3	12.2	4.41	4.51
8.5	CB27- 54H S52	3287000563	1-1/8" Sweat	1-1/8" Sweat	0.54	18.1	12.2	4.41	5.46
10	CB27- 64H S52	3287000564	1-1/8" Sweat	1-1/8" Sweat	0.65	21	12.2	4.41	6.4
5	AC50- 16HX S11	3287000709	1/2", 1-1/8" Sweat	1-1/8" Sweat	0.28	12.1	20.71	4.41	1.89
6.5	AC50- 20HX S11	3287000710	1/2", 1-1/8" Sweat	1-1/8" Sweat	0.36	14.1	20.71	4.41	2.28
8.5	AC50- 26HX S21	3287000715	5/8", 1-1/8" Sweat	1-1/8" Sweat	0.48	17.2	20.71	4.41	2.84
10.5	AC50- 32HX S21	3287000716	5/8", 1-1/8" Sweat	1-1/8" Sweat	0.6	20.2	20.71	4.41	3.43
12	AC50- 36HX S21	3287000717	5/8", 1-1/8" Sweat	1-1/8" Sweat	0.68	22.2	20.71	4.41	3.78
14.5	AC50- 42HX S21	3287000718	5/8", 1-1/8" Sweat	1-1/8" Sweat	0.8	25.3	20.71	4.41	4.37
15.5	AC50- 48HX S24	3287000719	5/8", 1-3/8" Sweat	1-1/8" Sweat	0.92	28.3	20.71	4.41	4.91
17	AC50- 54HX S24	3287000720	5/8", 1-3/8" Sweat	1-1/8" Sweat	1.04	31.4	20.71	4.41	5.51
19.5	AC50- 64HX S25	3287000721	5/8", 1-3/8" Sweat	1-3/8" Sweat	1.24	36.4	20.71	4.41	6.46
22	AC50- 70HX S25	3287000722	5/8", 1-3/8" Sweat	1-3/8" Sweat	1.36	39.5	20.71	4.41	7.01
20	AC120- 30EQ S46	3287000696	7/8", 2-1/8" Sweat	2-1/8" Sweat, 2-1/8" Sweat	1.2	45.8	24.29	7.56	3.21
26	AC120- 40EQ S46	3287000697	7/8", 2-1/8" Sweat	2-1/8" Sweat, 2-1/8" Sweat	1.61	55.6	24.29	7.56	4.13
30	AC120- 46EQ S62	3287000698	1-1/8", 2-1/8" Sweat	2-1/8" Sweat, 2-1/8" Sweat	1.88	61.4	24.29	7.56	4.69
40	AC120- 60EQ S62	3287000699	1-1/8", 2-1/8" Sweat	2-1/8" Sweat, 2-1/8" Sweat	2.48	75	24.29	7.56	5.98
48	AC120- 76EQ S62	3287000700	1-1/8", 2-1/8" Sweat	2-1/8" Sweat, 2-1/8" Sweat	3.15	90.5	24.29	7.56	7.46
55	AC120- 90EQ S62	3287000701	1-1/8", 2-1/8" Sweat	2-1/8" Sweat, 2-1/8" Sweat	3.76	104.1	24.29	7.56	8.76
59	AC120-106EQ S62	3287000702	1-1/8", 2-1/8" Sweat	2-1/8" Sweat, 2-1/8" Sweat	4.42	119.6	24.29	7.56	10.24
64	AC120-124EQ S62	3287000703	1-1/8", 2-1/8" Sweat	2-1/8" Sweat, 2-1/8" Sweat	5.19	137	24.29	7.56	11.91
80	AC120-150EQ S76	3287000704	1-3/8", 2-1/8" Sweat	2-1/8" Sweat, 2-1/8" Sweat	6.32	162.3	24.29	7.56	14.31
90	AC120-180EQ S76	3287000705	1-3/8", 2-1/8" Sweat	2-1/8" Sweat, 2-1/8" Sweat	7.6	191.4	24.29	7.56	17.09

*Operating Conditions: 110°F ELT, 50°F LLT, 40°F SST, 7" SH, ΔP_{liq}<2 psig, FF=0

**Estimated 15% liquid on S3-S4 side

Brazed plate heat exchangers can be used as desuperheaters to use water to remove superheat from the refrigerant gas from the compressor. This decreases the amount of heat that needs to be removed by the condenser. Typically, the cooling water is about 15°F lower than the refrigerant gas exit temperature. Desuperheaters are used to enhance system efficiency and recover heat.

Desuperheaters/Heat Reclaim

Desuperheaters/Heat Reclaim

Nominal Tons*	Denomination	Part Number	Connection Description		Operating Charge (R22)****	Dry Wt. (lbs.)	Dimensions		
			Refrigerant Inlet/Outlet (S3, S4)	Fluid Inlet/Outlet (S1, S2)			Height (in.)	Width (in.)	Plate Pack Length (in.)
0.5	Single Circuited CB14- 14H S15	3287000755	5/8" Sweat	5/8" Sweat	0.05	3.4	8.19	3.07	1.61
0.5	CB27- 12H S15	3287000754	5/8" Sweat	5/8" Sweat	0.1	6.1	12.2	4.41	1.49
1	CB27- 18H S33	3287000712	7/8" Sweat	7/8" Sweat	0.17	7.8	12.2	4.41	2.06
1.5	CB27- 24H S33	3287000713	7/8" Sweat	7/8" Sweat	0.23	9.5	12.2	4.41	2.62
1.75	CB27- 34H S52	3287000714	1-1/8" Sweat	1-1/8" Sweat	0.34	12.4	12.2	4.41	3.57
2.25	CB27- 44H S52	3287000562	1-1/8" Sweat	1-1/8" Sweat	0.44	15.3	12.2	4.41	4.51
2.5	CB27- 54H S52	3287000563	1-1/8" Sweat	1-1/8" Sweat	0.54	18.1	12.2	4.41	5.46
3.25	CB27- 64H S52	3287000564	1-1/8" Sweat	1-1/8" Sweat	0.65	21	12.2	4.41	6.4
2	**CB52-30L C65	CB52-30L C65	1-3/8" Sweat	1" Male NPT	3.1	19.2	20.71	4.41	3.21
3	**CB52-40L C65	CB52-40L C65	1-3/8" Sweat	1" Male NPT	4.3	24.3	20.71	4.41	4.15
4	**CB52-50L C65	CB52-50L C65	1-3/8" Sweat	1" Male NPT	5.4	29.3	20.71	4.41	5.09
4.5	**CB52-60L C65	CB52-60L C65	1-3/8" Sweat	1" Male NPT	6.5	34.4	20.71	4.41	6.03
5	**CB52-80L C65	CB52-80L C65	1-3/8" Sweat	1" Male NPT	8.8	44.5	20.71	4.41	7.91
5	**CB76-24M C79	CB76-24M C79	1-5/8" Sweat	2" Male NPT	7.8	40	24.29	7.56	2.99
6	**CB76-30M C79	CB76-30M C79	1-5/8" Sweat	2" Male NPT	9.9	45.9	24.29	7.56	3.65
8	**CB76-40M C79	CB76-40M C79	2-1/8" Sweat	2" Male NPT	13.4	55.6	24.29	7.56	4.75
12	**CB76-50M C79	CB76-50M C79	2-1/8" Sweat	2" Male NPT	16.9	65.3	24.29	7.56	5.86
14	**CB76-60M C79	CB76-60M C79	2-1/8" Sweat	2" Male NPT	20.5	75	24.29	7.56	6.95
16	**CB76-72M C79	CB76-72M C79	2-1/8" Sweat	2" Male NPT	24.7	86.6	24.29	7.56	8.27
19	**CB76-90M C79	CB76-90M C79	2-1/8" Sweat	2" Male NPT	31.1	104.1	24.29	7.56	1.26
22	**CB76-110M C79	CB76-110M C79	2-1/8" Sweat	2" Male NPT	38.1	123.5	24.29	7.56	12.45
	**CB76-150M C79	CB76-150M C79	2-1/8" Sweat	2" Male NPT	52.2	162.3	24.29	7.56	16.85

*Operating Conditions: 180°F EGT, 105°F LGT, 90°F EWT, 140°F LWT, $\Delta P_{ref} < 2$ psig, $P_w < 10$ psig, FF=0.0001 Ft², hr, °F/Btu

**Non-standard

***Estimated 15% liquid on S3-S4 side

Hydraulic oil systems are very common in the plastics, steel, pulp & paper industries, and any manufacturing industry that requires machines in the assembly process. This hydraulic oil needs to be maintained at the correct temperature for the equipment to run properly. Braze plate heat exchangers are an excellent choice for hydraulic oil cooling because their low hold-up volume allows for a very accurate temperature control. This chart is based on a typical installation using water to cool the hydraulic oil. For other applications, please contact Alfa Laval for design recommendations.

Hydraulic Oil Coolers

Hydraulic Oil Coolers

Btu/hr	Denomination	Part Number	Connection Description		ISO VG68 Oil		Water		Dry Wt. (lbs.)	Dimensions		
			Oil Inlet/Outlet (S1, S2)	Water Inlet/Outlet (S3, S4)	Flowrate GPM	Pressure Drop PSI	Flowrate GPM	Pressure Drop PSI		Height (in.)	Width (in.)	Plate Pack Length (in.)
15000	CB14- 14H T05	3287000604	3/4" Male NPT	3/4" Male NPT	8	7.5	4	1.7	3	8.19	3.07	1.61
25000	CB14- 20H T05	3287000605	3/4" Male NPT	3/4" Male NPT	14	11.3	7	2.4	3.7	8.19	3.07	2.17
34000	CB14- 28H T05	3287000606	3/4" Male NPT	3/4" Male NPT	18	10.3	9	2.1	4.5	8.19	3.07	2.91
25000	CB27- 10H T06	3287000691	1" Male NPT	1" Male NPT	8	13.5	4	3.4	5.5	12.2	4.41	1.3
44000	CB27- 18H T06	3287000619	1" Male NPT	1" Male NPT	12	10.3	6	1.9	7.8	12.2	4.41	2.06
56000	CB27- 24H T06	3287000620	1" Male NPT	1" Male NPT	14	8.7	7	1.4	9.5	12.2	4.41	2.62
82000	CB27- 34H T06	3287000621	1" Male NPT	1" Male NPT	20	8.9	10	1.4	12.4	12.2	4.41	3.57
108000	CB27- 44H T06	3287000692	1" Male NPT	1" Male NPT	26	9.2	13	1.4	15.3	12.2	4.41	4.51
125000	CB27- 50H T06	3287000622	1" Male NPT	1" Male NPT	30	9.5	15	1.5	17	12.2	4.41	5.09
150000	CB27- 60H T06	3287000693	1" Male NPT	1" Male NPT	36	9.8	18	1.6	19.9	12.2	4.41	6.06
172000	CB27- 70H T06	3287000623	1" Male NPT	1" Male NPT	40	9	20	1.5	22.7	12.2	4.41	6.97
237000	CB27-100H T06	3287000624	1" Male NPT	1" Male NPT	54	10.1	27	1.8	31.3	12.2	4.41	9.8
160000	CB76- 20H T09	3287000633	2" Male NPT	2" Male NPT	22	8.9	11	1.2	34.8	24.3	7.56	2.64
262000	CB76- 30H T09	3287000634	2" Male NPT	2" Male NPT	36	9.9	18	1.3	44.5	24.3	7.56	3.76
363000	CB76- 40H T09	3287000635	2" Male NPT	2" Male NPT	50	10.5	25	1.4	54.2	24.3	7.56	4.88
452000	CB76- 50H T09	3287000636	2" Male NPT	2" Male NPT	60	10	30	1.3	63.9	24.3	7.56	6
570000	CB76- 60H T09	3287000637	2" Male NPT	2" Male NPT	80	11.7	40	1.6	73.6	24.3	7.56	7.13
670000	CB76- 70H T09	3287000638	2" Male NPT	2" Male NPT	94	11.9	47	1.6	83.3	24.3	7.56	8.25
748000	CB76- 80H T09	3287000639	2" Male NPT	2" Male NPT	100	10.9	50	1.4	93	24.3	7.56	9.4
836000	CB76- 90H T09	3287000640	2" Male NPT	2" Male NPT	110	10.7	55	1.4	102.7	24.3	7.56	10.49
925000	CB76-100H T09	3287000641	2" Male NPT	2" Male NPT	120	10.6	60	1.4	112.4	24.3	7.56	11.61

Oil Type ISO VG68 (avg. viscosity 100 SSU), Oil to Water flow 2:1, Leaving oil temp. 120°F, Entering water temp. 80°F.

One of the newest and most efficient ways to offer comfort heating is with radiant floor heating. This is very popular in northern Europe but is quickly catching on in colder climates in North America. This chart is based on a typical installation using boiler water to heat the water that is pumped through the floor. For other applications, please contact Alfa Laval for design recommendations.

Radiant Floor Heat Exchangers

Radiant Floor Heat Exchangers

Btu/hr	Denomination	Part Number	Connection Description		Boiler Water		Floor Heat Water		Dry Wt. (lbs.)	Dimensions		
			Boiler Water Inlet/Outlet (S3, S4)	30% P.G. Inlet/Outlet (S1, S2)	Flowrate GPM	Pressure Drop PSI	Flowrate GPM	Pressure Drop PSI		Height (in.)	Width (in.)	Plate Pack Length (in.)
25000	CB14- 14H T05	3287000604	3/4" Male NPT	3/4" Male NPT	1.7	0.3	2.5	0.5	3	8.19	3.07	1.61
30000	CB14- 14H T05	3287000604	3/4" Male NPT	3/4" Male NPT	2.1	0.4	3	0.7	3	8.19	3.07	1.61
40000	CB14- 14H T05	3287000604	3/4" Male NPT	3/4" Male NPT	2.7	0.7	4	1.2	3	8.19	3.07	1.61
50000	CB14- 14H T05	3287000604	3/4" Male NPT	3/4" Male NPT	3.4	1.1	5	1.9	3	8.19	3.07	1.61
60000	CB14- 14H T05	3287000604	3/4" Male NPT	3/4" Male NPT	4.1	1.6	6	2.6	3	8.19	3.07	1.61
70000	CB14- 14H T05	3287000604	3/4" Male NPT	3/4" Male NPT	4.8	2	7	3.5	3	8.19	3.07	1.61
80000	CB14- 14H T05	3287000604	3/4" Male NPT	3/4" Male NPT	5.5	2.7	8	4.6	3	8.19	3.07	1.61
90000	CB14- 14H T05	3287000604	3/4" Male NPT	3/4" Male NPT	6.2	3.3	9	5.7	3	8.19	3.07	1.61
100000	CB14- 14H T05	3287000604	3/4" Male NPT	3/4" Male NPT	6.9	4	10	7	3	8.19	3.07	1.61
125000	CB14- 20H T05	3287000605	3/4" Male NPT	3/4" Male NPT	8.6	3	12.5	5.7	3.7	8.19	3.07	2.17
150000	CB14- 20H T05	3287000605	3/4" Male NPT	3/4" Male NPT	10.3	4.3	15	8	3.7	8.19	3.07	2.17
175000	CB14- 28H T05	3287000606	3/4" Male NPT	3/4" Male NPT	12	3.1	17.6	6.3	4.5	8.19	3.07	2.91
200000	CB14- 28H T05	3287000606	3/4" Male NPT	3/4" Male NPT	13.7	4	20	8.1	4.5	8.19	3.07	2.91
225000	CB27- 34H T06	3287000621	1" Male NPT	1" Male NPT	15.5	2.8	22.6	5.6	12.4	12.2	4.41	3.57
250000	CB27- 34H T06	3287000621	1" Male NPT	1" Male NPT	17.2	3.4	25.1	6.8	12.4	12.2	4.41	3.57
275000	CB27- 34H T06	3287000621	1" Male NPT	1" Male NPT	18.9	4.1	27.6	8.2	12.4	12.2	4.41	3.57
300000	CB27- 34H T06	3287000621	1" Male NPT	1" Male NPT	20.6	4.8	30.1	9.7	12.4	12.2	4.41	3.57

Selections based on 180°F Boiler Supply with 150°F return and 80°F Radiant Floor Return with 100°F Supply.

For safety concerns, many hospital and commercial buildings pump warm glycol to heat the sidewalks and entryways to melt snow and ice. The chart is based on a typical installation using boiler water to heat the glycol.

Snow Melt Heat Exchangers

Snow Melt Heat Exchangers

Btu/hr	Denomination	Part Number	Connection Description		Boiler Water		Floor Heat Water		Dry Wt. (lbs.)	Dimensions		
			Boiler Water Inlet/Outlet (S3, S4)	30% P.G. Inlet/Outlet (S1, S2)	Flowrate GPM	Pressure Drop PSI	Flowrate GPM	Pressure Drop PSI		Height (in.)	Width (in.)	Plate Pack Length (in.)
20000	CB14- 14H T05	3287000604	3/4" Male NPT	3/4" Male NPT	1.3	0.2	1.4	0.2	3	8.19	3.07	1.61
30000	CB14- 14H T05	3287000604	3/4" Male NPT	3/4" Male NPT	2.1	0.4	2.1	0.4	3	8.19	3.07	1.61
40000	CB14- 14H T05	3287000604	3/4" Male NPT	3/4" Male NPT	2.7	0.7	2.8	0.7	3	8.19	3.07	1.61
50000	CB14- 14H T05	3287000604	3/4" Male NPT	3/4" Male NPT	3.4	1.1	3.6	1.1	3	8.19	3.07	1.61
60000	CB14- 14H T05	3287000604	3/4" Male NPT	3/4" Male NPT	4.1	1.5	4.3	1.5	3	8.19	3.07	1.61
70000	CB14- 14H T05	3287000604	3/4" Male NPT	3/4" Male NPT	4.8	2.1	5	2	3	8.19	3.07	1.61
80000	CB14- 14H T05	3287000604	3/4" Male NPT	3/4" Male NPT	5.5	2.7	5.7	2.6	3	8.19	3.07	1.61
90000	CB14- 14H T05	3287000604	3/4" Male NPT	3/4" Male NPT	6.2	3.3	6.4	3.2	3	8.19	3.07	1.61
100000	CB14- 14H T05	3287000604	3/4" Male NPT	3/4" Male NPT	6.9	4.1	7.2	3.9	3	8.19	3.07	1.61
125000	CB14- 20H T05	3287000605	3/4" Male NPT	3/4" Male NPT	8.6	3	8.7	3	3.7	8.19	3.07	2.17
150000	CB14- 20H T05	3287000605	3/4" Male NPT	3/4" Male NPT	10.3	4.3	10.4	4.3	3.7	8.19	3.07	2.17
175000	CB14- 28H T05	3287000606	3/4" Male NPT	3/4" Male NPT	12	3.1	12.1	3.3	4.5	8.19	3.07	2.91
200000	CB14- 28H T05	3287000606	3/4" Male NPT	3/4" Male NPT	13.7	4	13.9	4.3	4.5	8.19	3.07	2.91
225000	CB27- 24H T06	3287000620	1" Male NPT	1" Male NPT	15.5	5.4	15.7	5.5	9.5	12.2	4.41	2.62
250000	CB27- 34H T06	3287000621	1" Male NPT	1" Male NPT	17.2	3.4	17.4	3.6	12.4	12.2	4.41	3.57
275000	CB27- 34H T06	3287000621	1" Male NPT	1" Male NPT	18.9	4	19.1	4.3	12.4	12.2	4.41	3.57
300000	CB27- 34H T06	3287000621	1" Male NPT	1" Male NPT	20.6	4.8	20.9	5.1	12.4	12.2	4.41	3.57
350000	CB27- 44H T06	3287000692	1" Male NPT	1" Male NPT	24	4	24.3	4.4	15.3	12.2	4.41	4.51
400000	CB27- 44H T06	3287000692	1" Male NPT	1" Male NPT	27.5	5.2	27.8	5.7	15.3	12.2	4.41	4.51
450000	CB27- 50H T06	3287000622	1" Male NPT	1" Male NPT	30.1	5.2	31	5.8	17	12.2	4.41	5.09
500000	CB27- 50H T06	3287000622	1" Male NPT	1" Male NPT	34.4	6.5	34.8	7.1	17	12.2	4.41	5.09

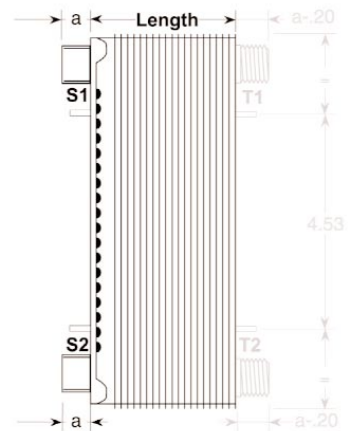
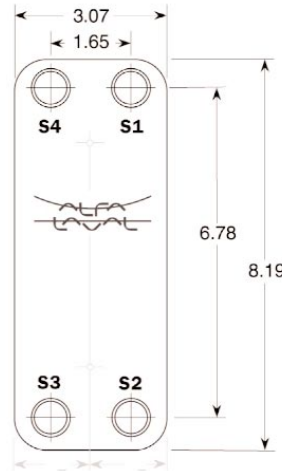
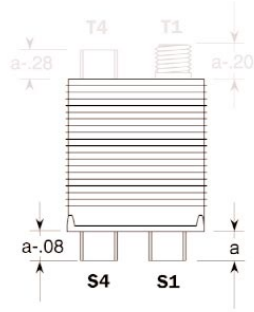
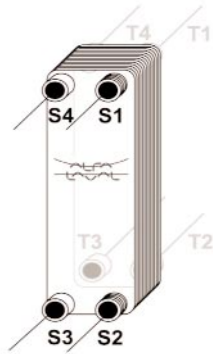

CB14

DIMENSIONS AND SPECIFICATIONS

Specifications	CB14
Pressure Range (PSIG)	Vacuum to 500
Temperature Range (°F)	-256°F to 437°F
Max. Connection Size (in.)	3/4
Maximum Flow Rate (gpm)	16
Volume/Channel (gallons)	0.005
Height (in.)	8.23
Width (in.)	3.07
Length Calculations (in.)	.32 + (n*.095)
Weight Calculations (lbs.)	1.5 + (n*.13)

n = number of plates

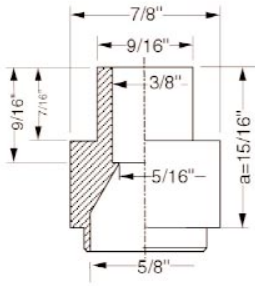

H27

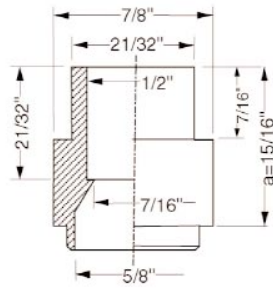

H24

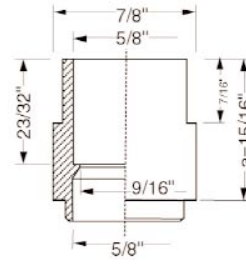

*H22

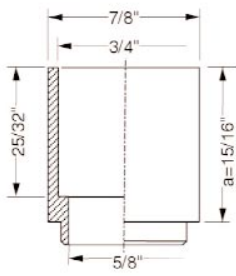

H26

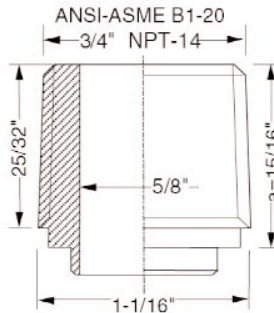

E21

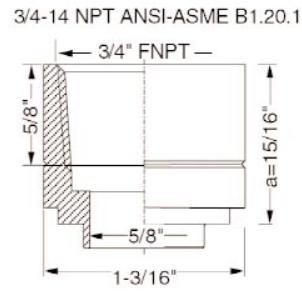

*C26

CB14

CONNECTIONS

Connection Type	Alfa Laval Part No.*	Internal Diameter	Cover Plate Hole Diameter	Height "a"
3/8" Sweat	H27	3/8"	.71	.95
1/2" Sweat	H24	1/2"	.71	.95
5/8" Sweat	H22	5/8"	.71	.95
3/4" Sweat	H26	3/4"	.71	.95
3/4" MaleNPT	E21	5/8"	.71	.95
3/4" FemaleNPT	C26	3/4"	.71	.95

*Letter denotes connection type:

C = Internal (female) threads

E = External tapered (conical) threads

H = Soldering

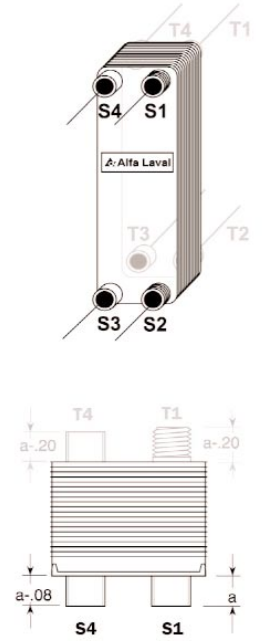
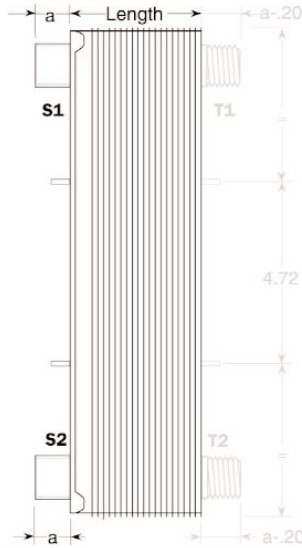
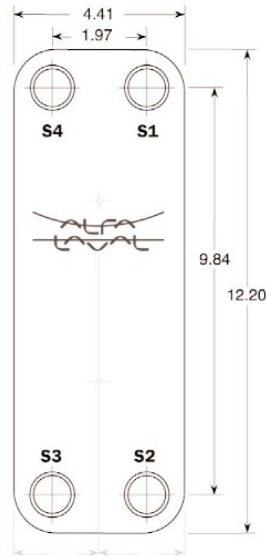

CB27

DIMENSIONS AND SPECIFICATIONS

Specifications	CB27
Pressure Range (PSIG)	Vacuum to 450
Temperature Range (°F)	-256°F to 437°F
Max. Connection Size (in.)	1-1/8
Maximum Flow Rate (gpm)	40
Volume/Channel (gallons)	0.013
Height (in.)	12.20
Width (in.)	4.41
Length Calculations (in.)	$.32 + (n \cdot .095)$
Weight Calculations (lbs.)	$2.6 + (n \cdot .29)$

n = number of plates

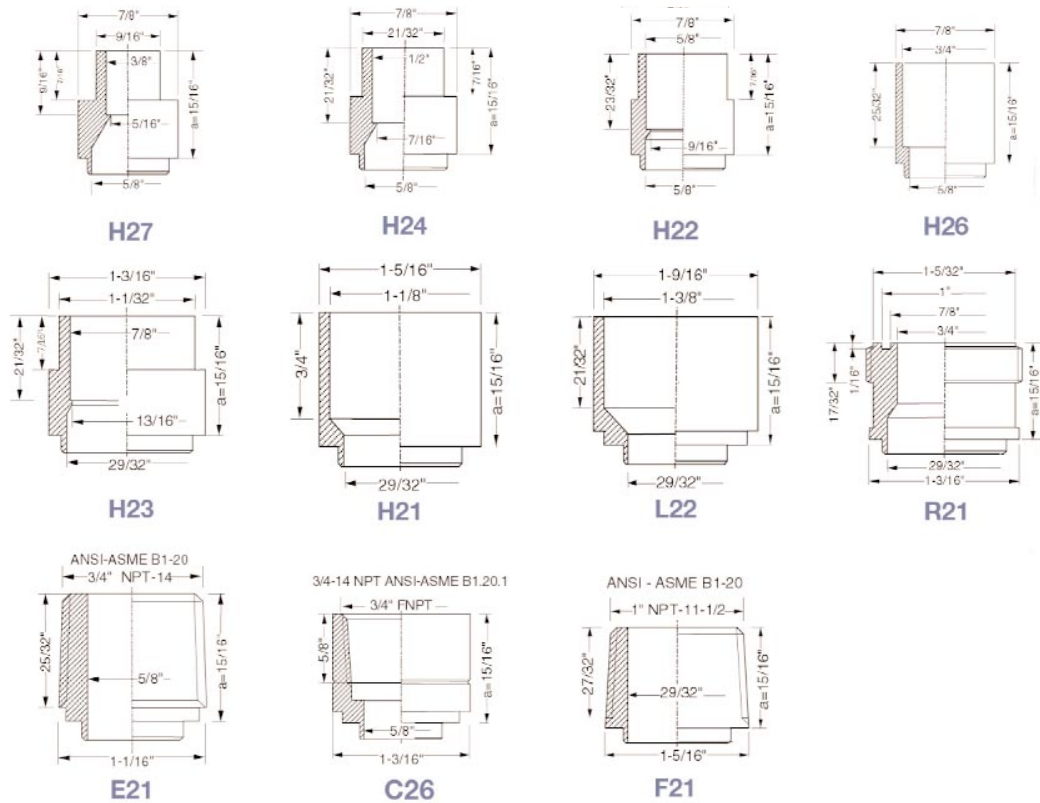

CB27

CONNECTIONS

Connection Type	Alfa Laval Part No.*	Internal Diameter	Cover Plate Hole Diameter	Height "a"
3/8" Sweat	H27	3/8"	.71	.95
1/2" Sweat	H24	1/2"	.71	.95
5/8" Sweat	H22	5/8"	.71	.95
3/4" Sweat	H26	3/4"	.71	.95
7/8" Sweat	H23	7/8"	.98	.95
1-1/8" Sweat	H21	1-1/8"	.98	.95
1-3/8" Sweat	L22	1-3/8"	.98	.95
1-1/4" Roto Lock™	R21	3/4"	.98	.95
3/4" MaleNPT	E21	5/8"	.71	.95
3/4" FemaleNPT	C26	3/4"	.71	.95
1" MaleNPT	F21	29/32"	.98	.95

*Letter denotes connection type:

C = Internal (female) threads

E,F = External tapered (conical) threads

H,L = Soldering

R = Roto Lock: UNEF (ANSI B 1.1 - 1982) Threaded connection with a groove suitable for an O-ring at the tightening surface.

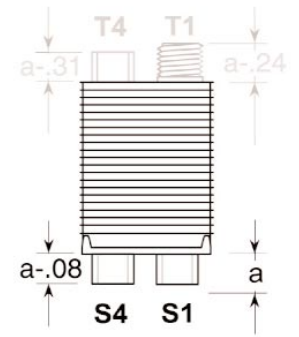
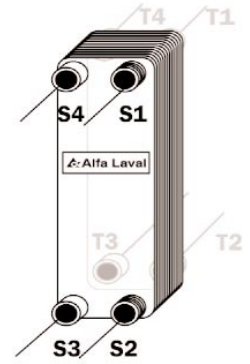
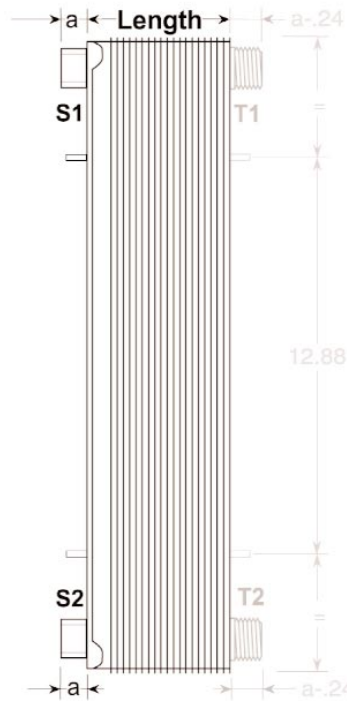
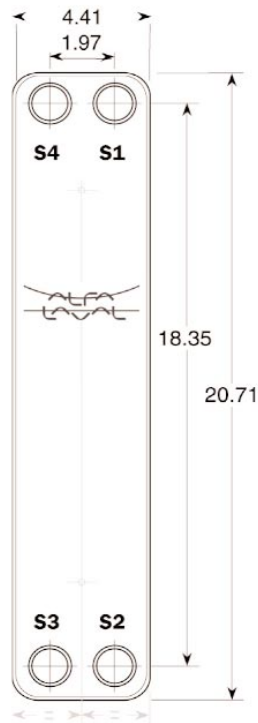

CB52/AC50

DIMENSIONS AND SPECIFICATIONS

Specifications	CB52/AC50
Pressure Range (PSIG)	Vacuum to 450
Temperature Range (°F)	-256°F to 437°F
Max. Connection Size (in.)	1-1/8
Maximum Flow Rate (gpm)	40
Volume/Channel (gallons)	0.021
Height (in.)	20.71
Width (in.)	4.41
Length Calculations (in.)	.39 + (n*.094)
Weight Calculations (lbs.)	4.0 + (n*.51)

n = number of plates

AC50

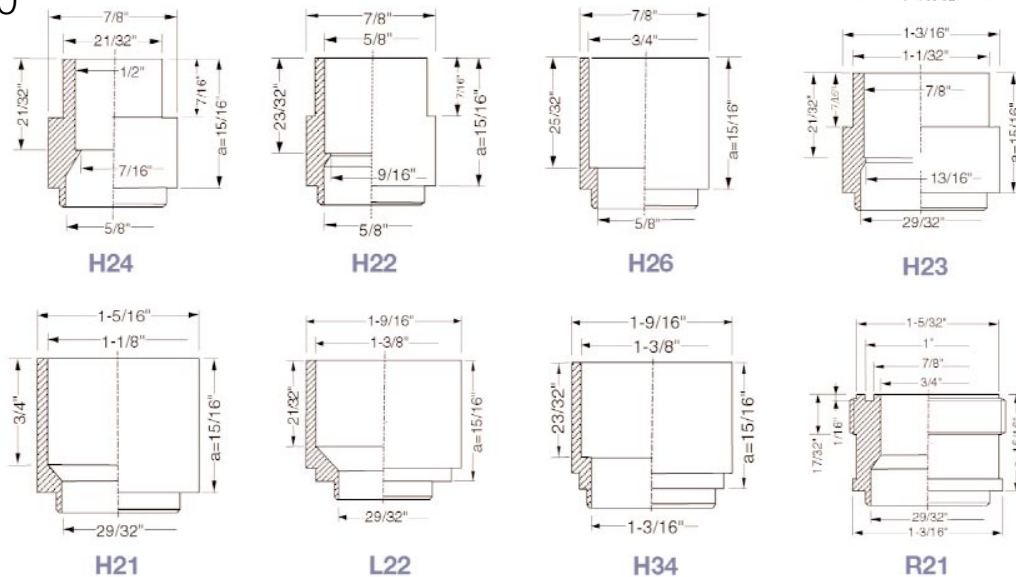

CB52

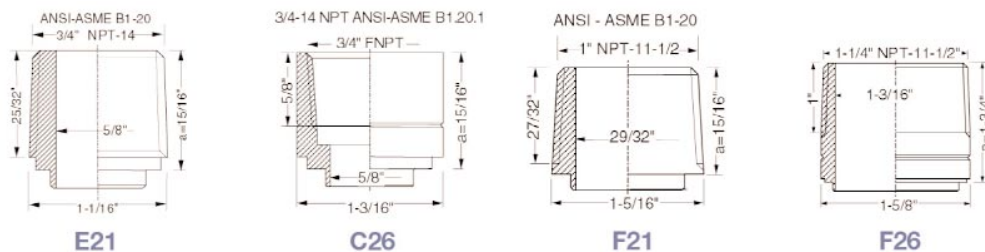

CB52/AC50

CONNECTIONS

Connection Type	Alfa Laval Part No.*	Internal Diameter	Cover Plate Hole Diameter	Height "a"
1/2" Sweat	H24	1/2"	.71	.95
5/8" Sweat	H22	5/8"	.71	.95
3/4" Sweat	H26	3/4"	.71	.95
7/8" Sweat	H23	7/8"	.98	.95
1-1/8" Sweat	H21	1-1/8"	.98	.95
1-3/8" Sweat	L22	1-3/8"	.98	.95
1-3/8" Sweat	H34	1-3/8"	1.58	.95
1-1/4" Roto Lock™	R21	3/4"	.98	.95
3/4" MaleNPT	E21	5/8"	.71	.95
3/4" FemaleNPT	C26	3/4"	.71	.95
1" MaleNPT	F21	29/32"	.98	.95
1-1/4" MaleNPT	F26	1-3/16"	1.25	1.75

*Letter denotes connection type:

C = Internal (female) threads

H,L = Soldering

E,F = External tapered (conical) threads

R = Roto Lock: UNEF (ANSI B 1.1 - 1982) Threaded connection with a groove suitable for an O-ring at the tightening surface.

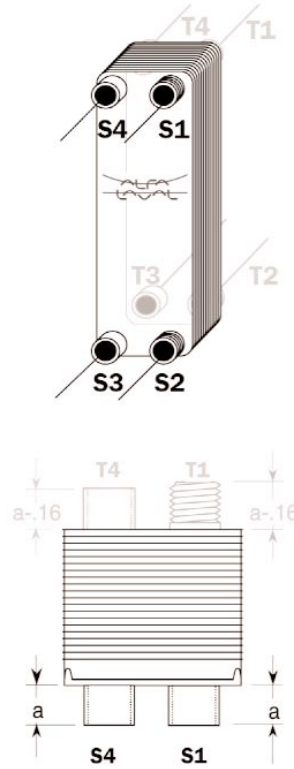
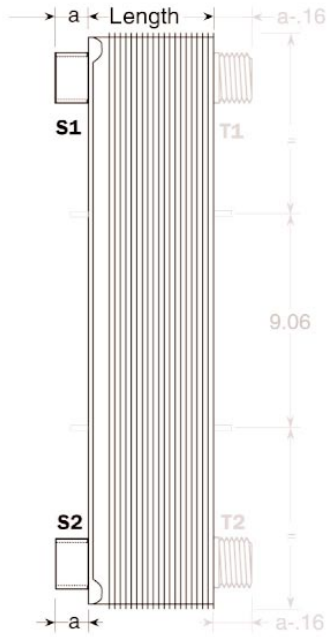
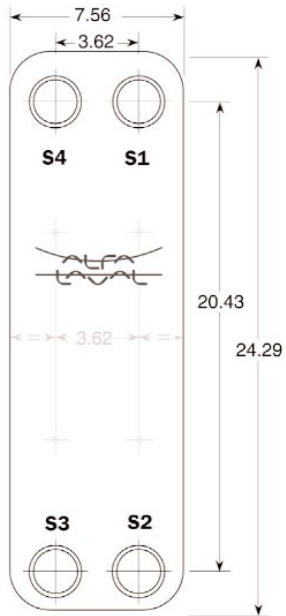

CB76

DIMENSIONS AND SPECIFICATIONS

Specifications	CB76
Pressure Range (PSIG)	Vacuum to 435
Temperature Range (°F)	-256°F to 437°F
Max. Connection Size (in.)	2-1/2
Maximum Flow Rate (gpm)	150
Volume/Channel (gallons)	0.066
Height (in.)	24.29
Width (in.)	7.56
Length Calculations (in.)	$.39 + (n \cdot .111)$
Weight Calculations (lbs.)	$16.8 + (n \cdot .97)$

n = number of plates

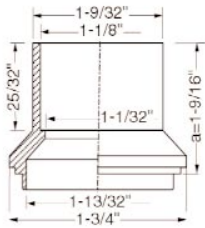

D27

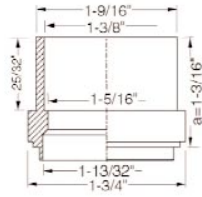

D26

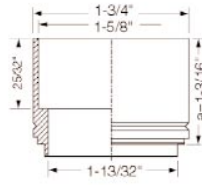

H25

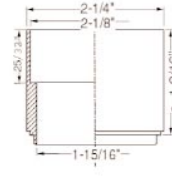

D21

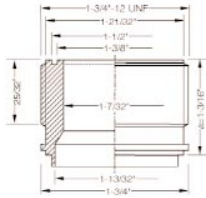

R22

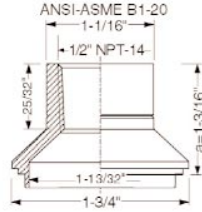

F38

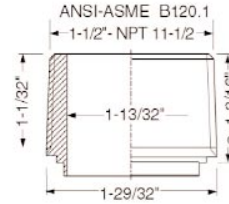

F23

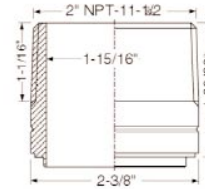

F22

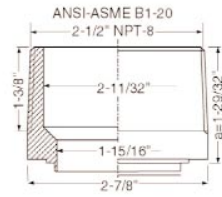

F34

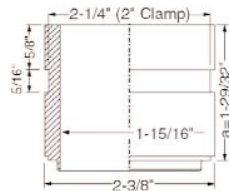

P23

CB76

CONNECTIONS

Connection Type	Alfa Laval Part No.*	Internal Diameter	Cover Plate Hole Diameter	Height "a"
1-1/8" Sweat	D27	1-1/8"	1.5	1.18
1-3/8" Sweat	D26	1-3/8"	1.5	1.18
1-5/8" Sweat	H25	1-5/8"	1.5	1.18
2-1/8" Sweat	D21	2-1/8"	2.0	1.58
1-3/4" Roto Lock™	R22	1-7/32"	1.5	1.18
1/2" FemaleNPT	F38	1/2"	1.5	1.18
1-1/2" MaleNPT	F23	1-13/32"	1.5	1.18
2" MaleNPT	F22	1-15/16"	2.0	1.89
2-1/2" MaleNPT	F34	2-3/8"	2.0	1.89
2" Victaulic®	P23	1-15/16"	2.0	1.89

*Letter denotes connection type:

D,H,L = Soldering

F = External tapered (conical) threads

P = Victaulic

R = Roto Lock: UNEF (ANSI B 1.1 - 1982) Threaded connection with a groove suitable for an O-ring at the tightening surface.

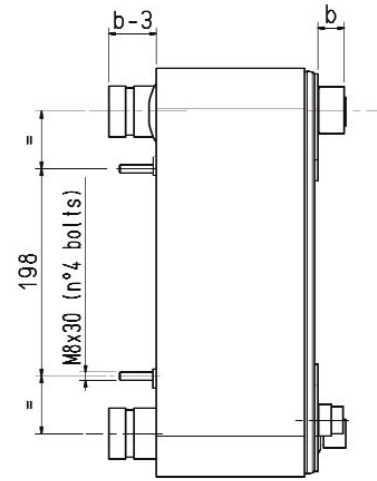
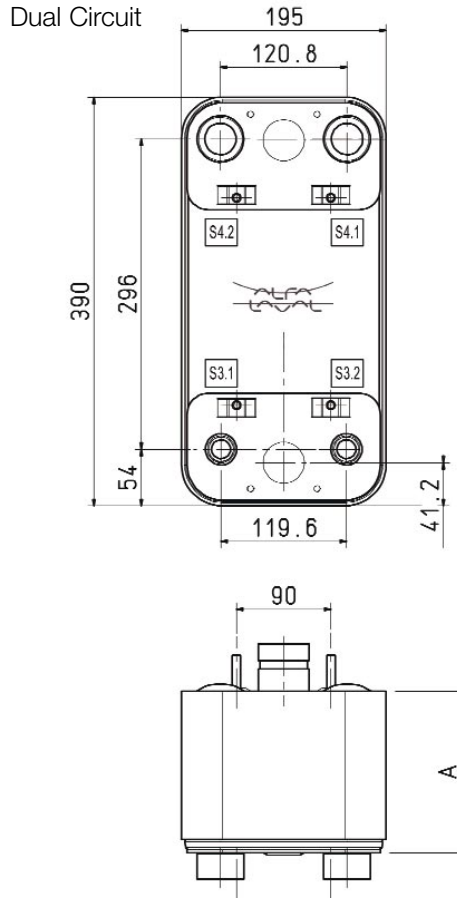
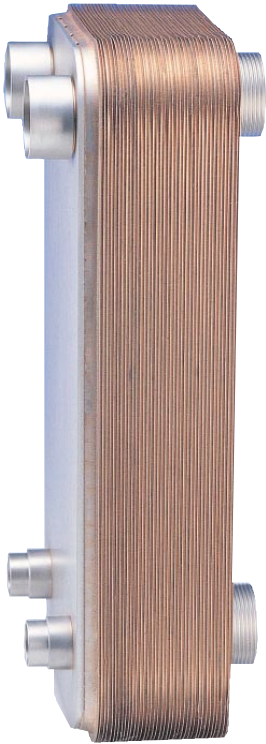

2 Cir. Freon + 1 Cir. Water

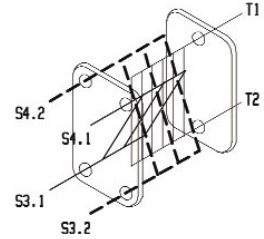

AC80

DIMENSIONS AND SPECIFICATIONS

Specifications	AC80
Pressure Range (PSIG)	Vacuum to 450
Temperature Range (°F)	-256°F to 437°F
Max. Connection Size (in.)	1-1/8
Maximum Flow Rate (gpm)	40
Volume/Channel (gallons)	0.021
Height (in.)	20.71
Width (in.)	4.41
Length Calculations (in.)	.39 + (n*.094)
Weight Calculations (lbs.)	4.0 + (n*.51)

n = number of plates

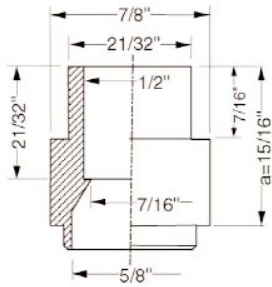

H24

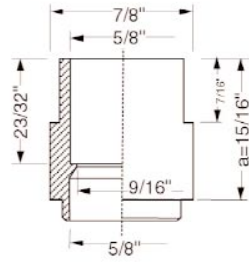

***H22**

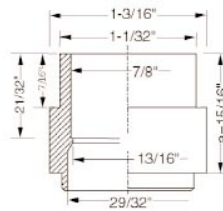

H23

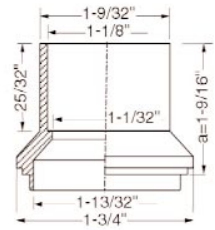

D27

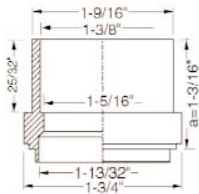

D26

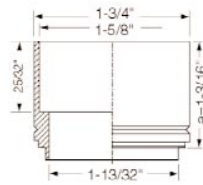

H25

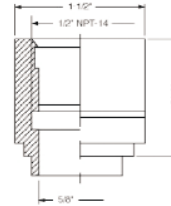

F36

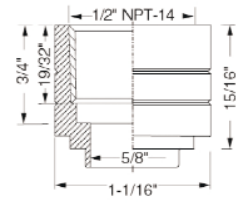

F37

AC80

CONNECTIONS

Connection Type	Alfa Laval Part No.*	Internal Diameter	Cover Plate Hole Diameter	Height "a"
1/2" Sweat	H24	1/2"	.71	.95
5/8" Sweat	H22	5/8"	.71	.95
7/8" Sweat	H23	7/8"	.98	.95
1-3/8" Sweat	D26	1-3/8"	1.5	1.58
1-1/8" Sweat	D27	1-1/8"	1.5	1.18
1-5/8" Sweat	H25**	1-5/8"	1.5	1.18
3/4" FemaleNPT	E36	3/4"	.95	.95
1/4" FemaleNPT	F36**	1/4"	0.71	.95
1/2" FemaleNPT	F37**	1/2"	0.71	.95

*Letter denotes connection type:

D,H = Soldering

E,F = External tapered (conical) threads

**Non-standard

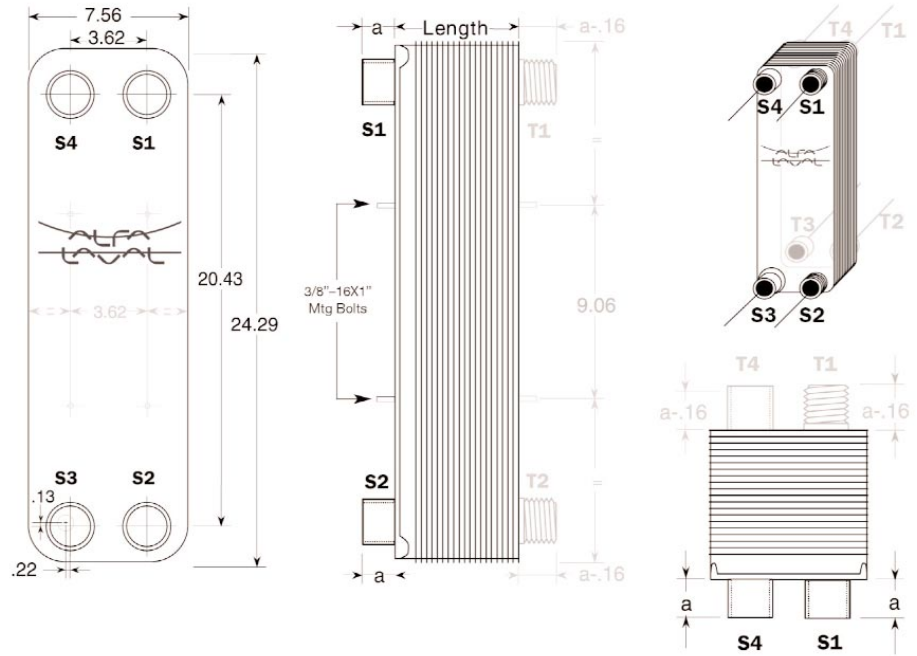
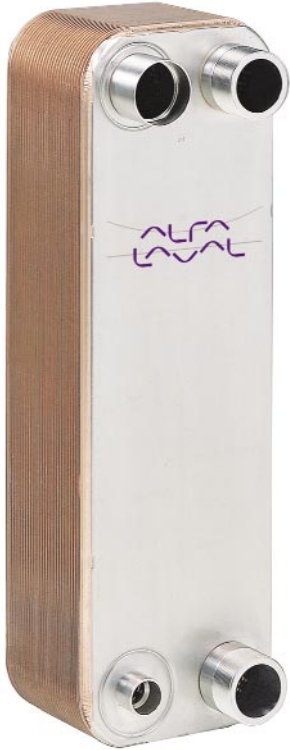

AC120

DIMENSIONS AND SPECIFICATIONS

Specifications	AC120
Pressure Range (PSIG)	Vacuum to 450
Temperature Range (°F)	-256°F to 437°F
Max. Connection Size (in.)	2-1/2
Maximum Flow Rate (gpm)	150
Volume/Channel (gallons)	0.053
Height (in.)	24.29
Width (in.)	7.56
Length Calculations (in.)	$.45 + (n \cdot .094)$
Weight Calculations (lbs.)	$16.8 + (n \cdot .97)$

n = number of plates

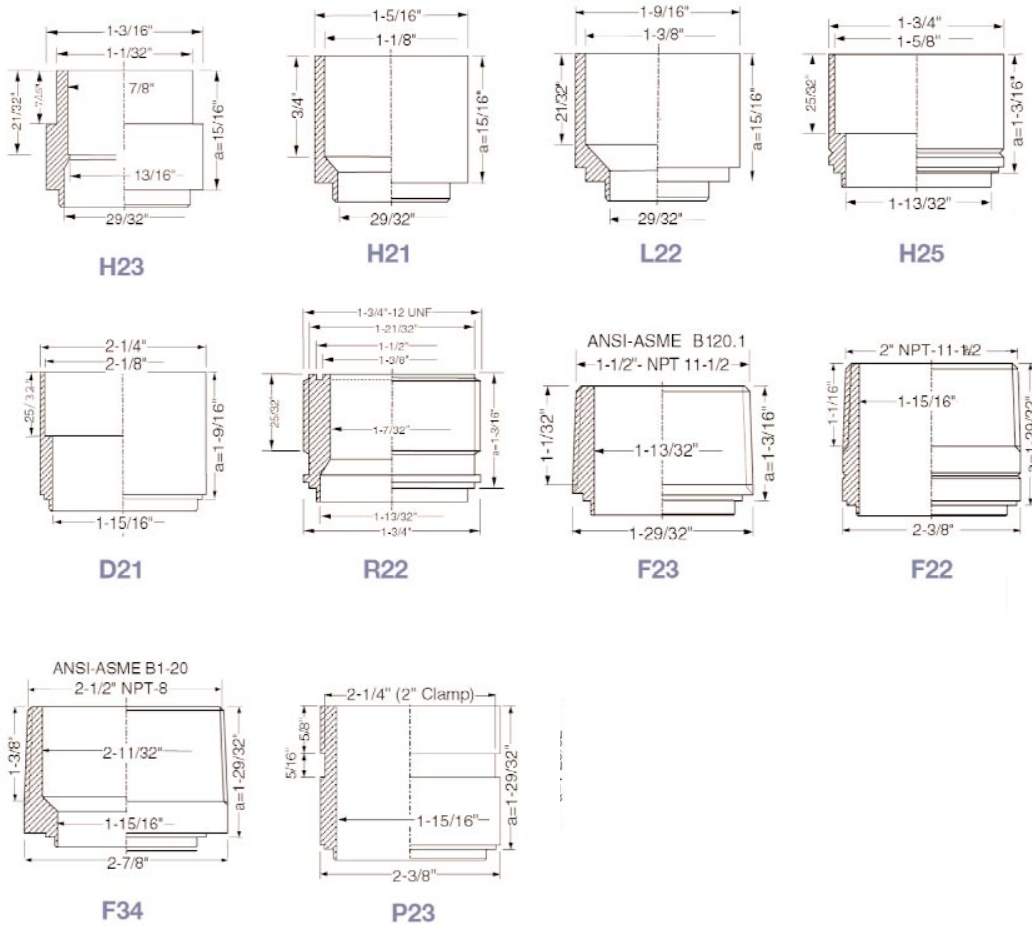

AC120 CONNECTIONS

Connection Type	Alfa Laval Part No.*	Internal Diameter	Cover Plate Hole Diameter	Height "a"
7/8" Sweat	H23	7/8"	.98	.95
1-1/8" Sweat	H21	1-1/8"	.98	.95
1-3/8" Sweat	L22	1-3/8"	.98	.95
1-5/8" Sweat	H25	1-5/8"	1.5	1.18
2-1/8" Sweat	D21	2-1/8"	2.0	1.58
1-3/4" Roto Lock™	R22	1-7/32"	1.5	1.58
1-1/2" MaleNPT	F23	1-13/32"	1.5	1.18
2" MaleNPT	F22	1-15/16"	2.0	1.89
2-1/2" MaleNPT	F34	2-3/8"	2.0	1.89
2" Victaulic®	P23	1-15/16"	2.0	1.89

*Letter denotes connection type:

D,H,L = Soldering

F = External tapered (conical) threads

P = Victaulic

R = Roto Lock: UNEF (ANSI B 1.1 - 1982) Threaded connection with a groove suitable for an O-ring at the tightening surface.

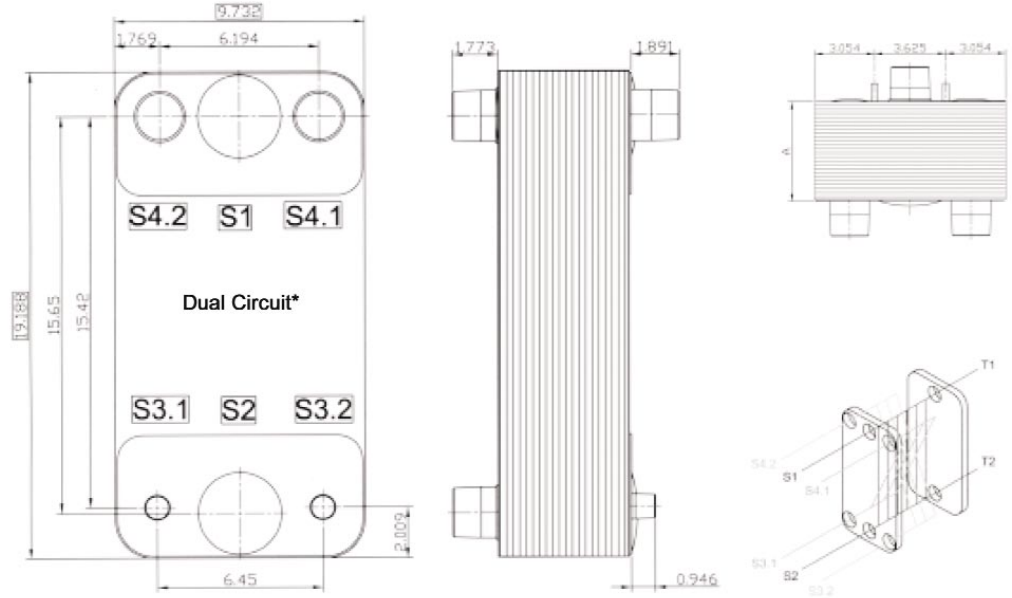

AC130

DIMENSIONS AND SPECIFICATIONS

Specifications	AC130
Pressure Range (PSIG)	Vacuum to 435/450 [†]
Temperature Range (°F)	-256°F to 437°F
Max. Connection Size (in.)	2-1/2
Maximum Flow Rate (gpm)	150
Volume/Channel (gallons)	0.043
Height (in.)	19.18
Width (in.)	9.73
Length Calculations (in.)	.31 + (n*.088)
Weight Calculations (lbs.)	14.3 + (n*.84)

[†]Channels S1 & S2/Channels S3 & S4
n = number of plates

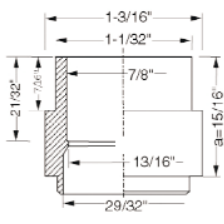

H23

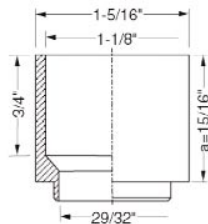

H21

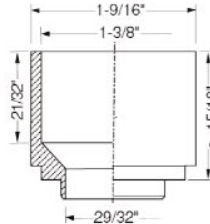

L22

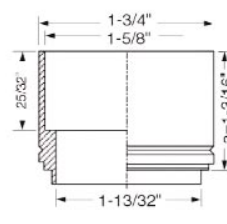

H25

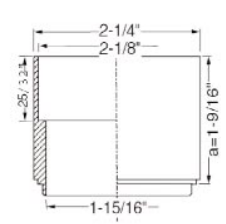

D21

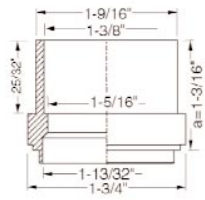

D26

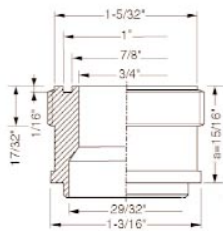

R21

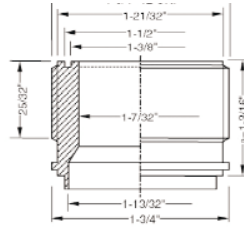

R22

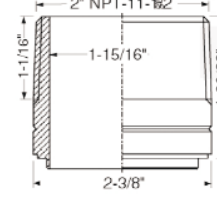

E38

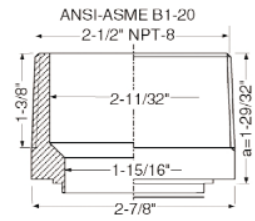

E39

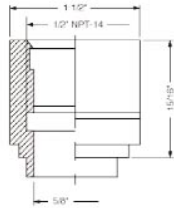

F36

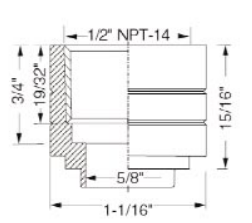

F37

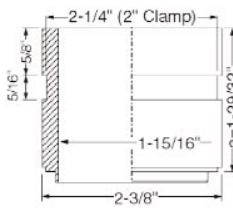

P32

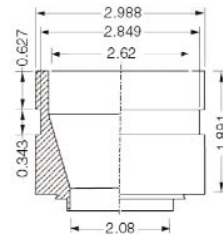

P31

AC130 CONNECTIONS

Connection Type	Alfa Laval Part No.*	Internal Diameter	Cover Plate Hole Diameter	Height "a"
**7/8" Sweat	H23	7/8"	.98	.95
1-1/8" Sweat	H21**	1-1/8"	.98	.95
1-3/8" Sweat	L22**	1-3/8"	.98	.95
1-5/8" Sweat	H25**	1-5/8"	1.5	1.18
**2-1/8" Sweat	D21	2-1/8"	2.0	1.58
1-3/8" Sweat	D26**	1-3/8"	1.5	1.58
1-1/4" Roto Lock™	R21**	3/4"	.098	.095
1-3/4" Roto Lock™	R22**	1-7/32"	1.5	1.58
1-1/4" Roto Lock™	R35**	1-9/16"	2.0	1.89
2" MaleNPT	E38**	1-15/16"	2.0	1.89
2-1/2" MaleNPT	E39	2-3/8"	2.0	1.89
1/2" FemaleNPT	F36**	1/2"	0.71	.95
3/4" FemaleNPT	F37**	3/4"	0.71	.95
2" Victaulic®	P32**	1-15/16"	2.0	1.89
2-1/2" Victaulic®	P31**	2-2/32"	2.16	1.89

*Letter denotes connection type:
 D,H,L = Soldering
 E = External tapered (conical) threads
 F = Internal tapered (conical) threads
 P = Victaulic
 R = Roto Lock: UNEF (ANSI B 1.1 - 1982)
 Threaded connection with a groove suitable for an O-ring at the tightening surface.

**Non-standard

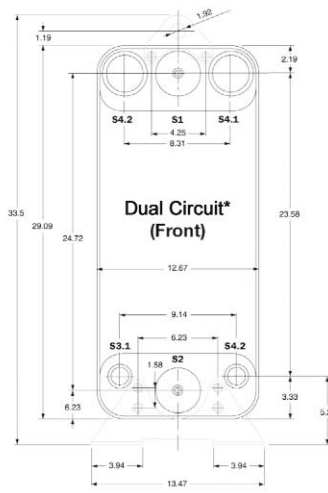
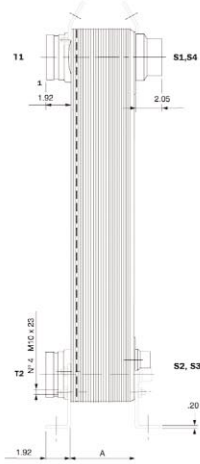

*Optional water connections on back side T1, T2.
Optional Temperature Sensor Well S1, S2.

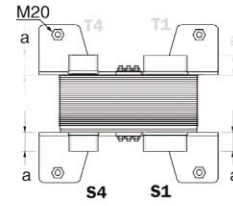

AC250

DIMENSIONS AND SPECIFICATIONS

Specifications	AC130
Pressure Range (PSIG)	Vacuum to 362/450 [†]
Temperature Range (°F)	-256°F to 437°F
Max.Connection Size (in.)	3-1/8
Maximum Flow Rate (gpm)	460
Volume/Channel (gallons)	0.100
Height (in.)	33.50
Width (in.)	12.68
Length Calculations (in.)	.53 + (n*.111)
Weight Calculations (lbs.)	22.3 + (n*1.76)

[†]Channels S1 & S2/Channels S3 & S4
n = number of plates

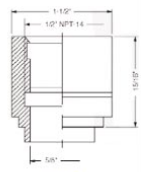

E37

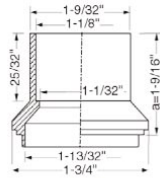

D27

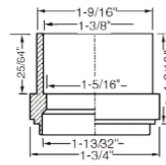

D26

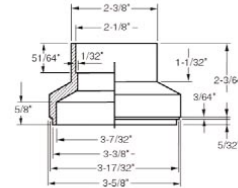

L34

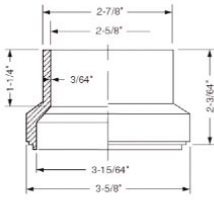

L33

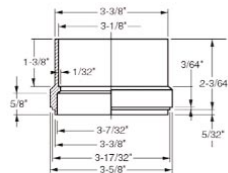

L35

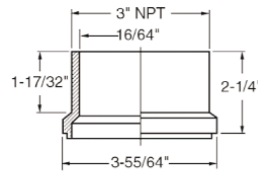

F35

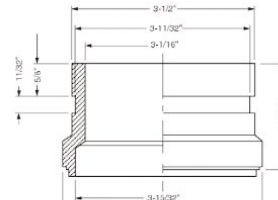

P35

AC250

CONNECTIONS

Connection Type	Alfa Laval Part No.*	Internal Diameter	Height "a"
1/2" FemaleNPT	E37	1/2"	.95
3/4" FemaleNPT	E36	3/4"	.95
1-1/8" Sweat	D27	1-1/8"	1.18
1-3/8" Sweat	D26	1-3/8"	1.18
2-1/8" Sweat	L34	2-1/8"	2.05
2-3/8" Sweat	L36	2-1/8"	2.05
2-5/8" Sweat	L33	2-5/8"	2.05
3-1/8" Sweat	L35	3-1/8"	2.05
2" MaleNPT	F30	2"	2.05
3" MaleNPT	F35	3"	2.05
2-1/2" Victaulic®	P34	2-5/8"	2.05
3" Victaulic	P35	3-1/16"	2.05

*Letter denotes connection type:

E = Internal (female) threads

F = External tapered (conical) threads

D,L = Soldering

P = Victaulic

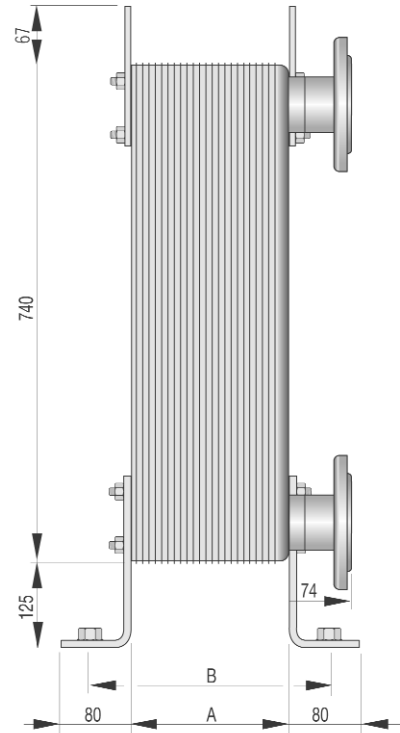
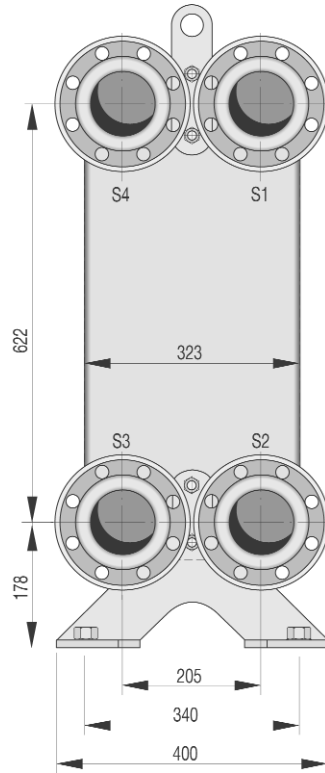

CB200

DIMENSIONS AND SPECIFICATIONS

Specifications	CB200
Pressure Range (PSIG)	Vacuum to 435
Temperature Range (°F)	-256°F to 437°F
Max. Connection Size (in.)	3-1/2
Maximum Flow Rate (gpm)	615
Volume/Channel (gallons)	0.13
Height (in.)	31.48
Width (in.)	15.74
Length Calculations (in.)	$.39 + (n \cdot 1.11)$
Weight Calculations (lbs.)	$29 + (n \cdot 1.32)$

n = number of plates

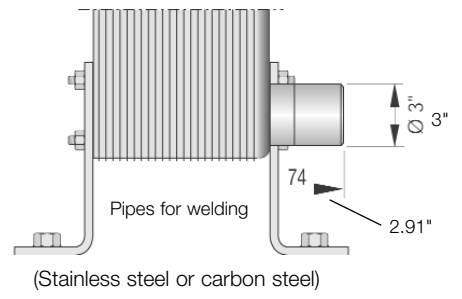
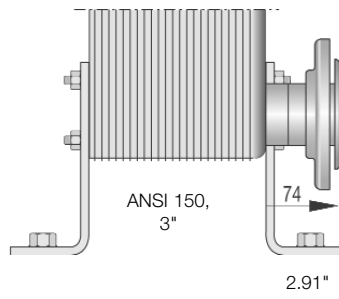
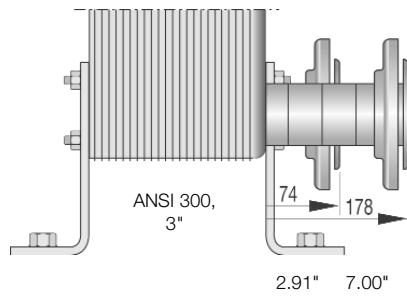

CB200

CONNECTIONS

Connection Type
3" Victaulic
3" DIN flange
3" ANSI weld

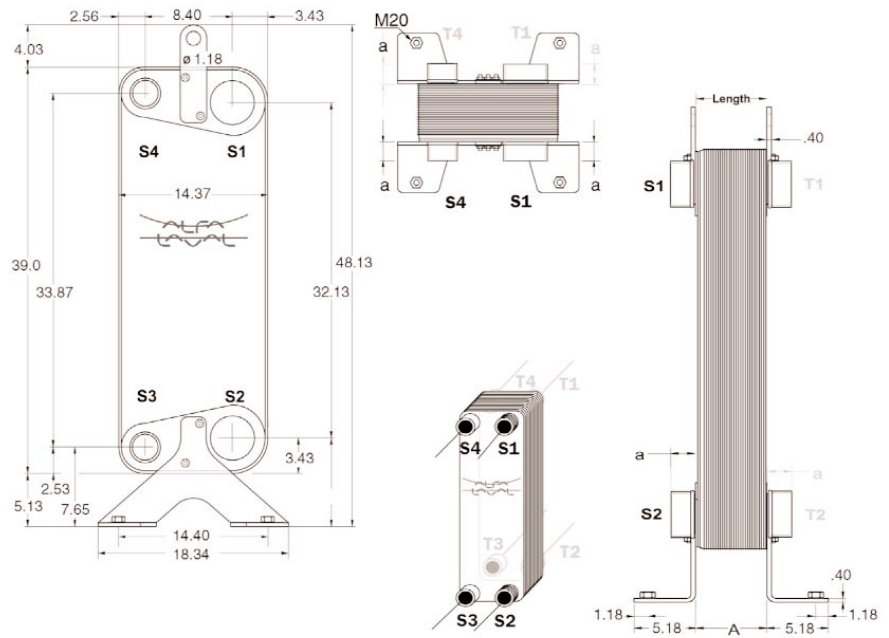

CB300

DIMENSIONS AND SPECIFICATIONS

Specifications	CB300
Pressure Range (PSIG)	Vacuum to 300/370 [†]
Temperature Range (°F)	-256°F to 437°F
Max.Connection Size (in.)	4-1/8
Maximum Flow Rate (gpm)	[†] 615/256
Volume/Channel (gallons)	0.172
Height (in.)	48.15
Width (in.)	14.37
Length Calculations (in.)	.63 + (n*.1103)
Weight Calculations (lbs.)	125.7 + (n*2.78)

[†]Channels S1 & S2/Channels S3 & S4
n = number of plates

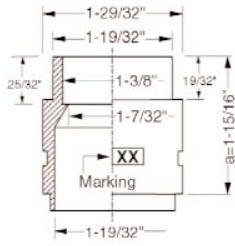

1-3/8" ODS

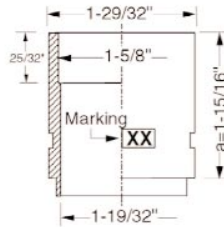

1-5/8" ODS

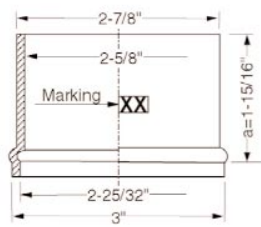

2-5/8" ODS

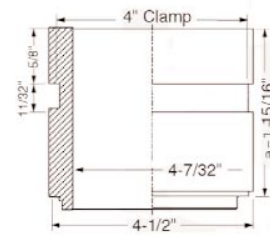

4" Victaulic

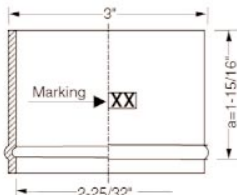

3" WN

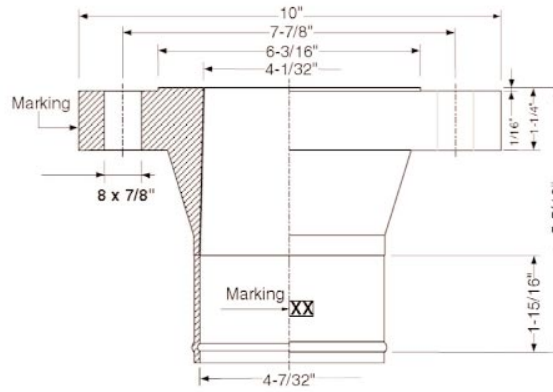

4" Flange

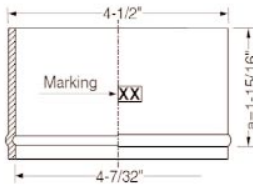

4-1/2" WN

CB300

CONNECTIONS

Connection Type	Alfa Laval Part No.*	Internal Diameter	Cover Plate Hole Diameter	Height "a"
1-3/8" Sweat	1-3/8" ODS	1-3/8"	1.7	1.95
1-5/8" Sweat	1-5/8" ODS	1-5/8"	1.7	1.95
2-5/8" Sweat	2-5/8" ODS	2-5/8"	3.0	1.95
3" WN	3" WN	2-25/32"	3.0	1.95
4-1/2" WN	4-1/2" WN	4-7/32"	4.5	1.95
4" Victaulic®	4" Victaulic®	3-15/16"	4.5	1.95
4" Flange	4" Flange	4"	4.5	5.31

*Letter denotes connection type:
 ODS = Outer diameter soldering of the connecting pipe, if applicable
 WN = Weld Neck

Alfa Laval in brief.

Alfa Laval is a leading global provider of specialized products and engineered solutions.

Our equipment, systems and services are dedicated to helping customers to optimize the performance of their processes. Time and time again.

We help our customers to heat, cool, separate and transport products such as oil, water, chemicals, beverages, foodstuff, starch and pharmaceuticals.

Our worldwide organization works closely with customers in almost 100 countries to help them stay ahead.

ALFA LAVAL is a registered trademark of Alfa Laval Corporate AB.

©2003 Alfa Laval

ENSR00005EN 0207

How to contact Alfa Laval

Contact details for all countries are continually updated on our website. Please visit www.alfalaval.com to access the information directly.